



ISO 9001 CERTIFIED

# BRAKE CABLE AND LEVER SYSTEMS



**WESCON CONTROLS**

# WESCON'S BRAKE CABLES, LEVERS AND KITS



## Brake Cables

Wescon brake cables are designed to allow high loads to be carried with low compressive deflection. This provides safe and efficient performance of your brake system.



## Ratcheting Brake Levers

Wescon's ratcheting brake levers allow progressive tension adjustments when applying the brake and a push button release for disengaging.



## Custom Brake Cables

Wescon's engineers can customize a brake cable to fit your application. From hard to reach locations to harsh environmental conditions, Wescon has the solution.

Wescon can also design a brake lever control system to meet your requirements.

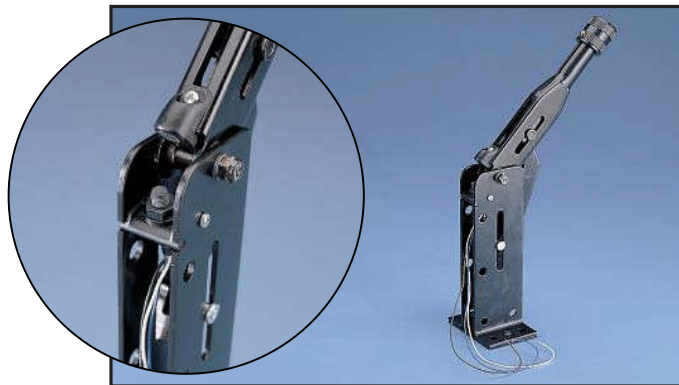

## Brake Levers

## Electric Switch

Wescon has developed the ability to install a magnetic electric switch in any of our over-center brake levers. This switch is environmentally sealed and can be easily installed by Wescon or the customer.



## Over-Center Brake Levers

Wescon has available nine different styles of over-center brake levers. Our levers offer a welded construction with a durable matte black, powder coat finish to prevent corrosion.



## Connection Hardware Kits

Wescon offers connection kit hardware to join your brake lever and cable. Our zinc cobalt plated components prevent corrosion which means a reliable brake cable system.



## Conduit

### CONSTRUCTION

The conduit construction is a **Bowden Flat Wire** design, made from galvanized spring steel wire. This type of construction is extremely effective in providing high loading with low compressive deflection in brake cable control assemblies. It is designed to combine **flexibility**, for ease of installation, and **high performance** requirements of a safe and reliable brake cable system.

### LINER

The liner of our Standard Series Brake Cable is made from **High Density Polyethylene (HDPE)**, especially formulated for **maximum efficiency**. Our Premium Series Brake Cable features a **self-lubricating Nylon** liner for use in **high temperature** applications.

### COVERING

Our special formulated conduit coverings seal out environmental contaminants and dirt while resisting abrasions and common solvents. Our Standard Series Brake Conduit features a **HDPE** covering, while our Premium Series .125 dia. Brake Conduit features a **Nylon** covering for **high temperature** applications.

### FITTINGS

A variety of conduit fittings are available to satisfy most requirements. Special fittings are available upon request. All fittings are **zinc-cobalt plated steel** exceeding a 96-hour salt spray corrosion resistance test and swaged to the conduit resulting in a highly secure installation.

**Internal seals** to inhibit entry of dirt and contaminants into the cable. These specially designed seals provide a smooth sliding **wear surface** for the Inner Core, resulting in a highly efficient, long life brake cable.

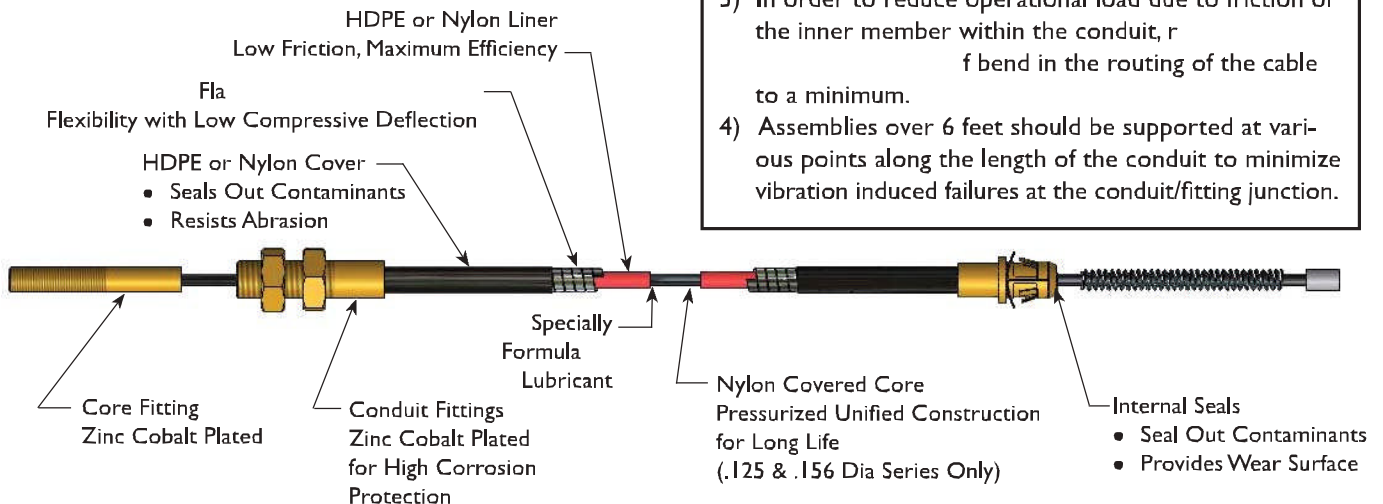

## Inner-Core

### CONSTRUCTION

On the .125 and .156 diameter series brake cables the inner core is manufactured with pre-formed high-tensile **1 x 19** galvanized steel strand and covered with a highly efficient self-lubricating nylon jacket. In the covering process the nylon jacket is pressurized onto the strand providing a unified construction with improved efficiency and reduced wear of the inner core. This design results in a flexible, easily operated control assembly with low deflection and increased cycle life. On the .187 diameter series brake cable the inner core is a bare **1 x 37** galvanized steel strand.

### FITTINGS

A variety of end fittings such as clevis and lug fittings and end rods are available. All fittings are **zinc cobalt plated steel** for additional corrosion protection and swaged to the inner core to hold the specified load of the cable assembly.

### LUBRICATION

The inner-core is lubricated with a specially formulated lubricant and is factory installed for years of efficient and maintenance-free operation.

As an alternative for demanding applications, Wescon has developed a proprietary lube, especially formulated for antifreeze protection, which is available at additional cost.

### NOTE: Brake Cable Installation

It should be taken when installing brake cable assemblies:

- 1) A sketch of the proposed installation will help Wescon Engineering select the proper control for your needs. A Wescon engineering drawing will be made. The design will then be approved by you and a sample will be provided for you to check for proper fit in the application to complete the design process.
- 2) Conduit fittings should be securely fastened to a structural member or rigid support.
- 3) In order to reduce operational load due to friction of the inner member within the conduit, reduce the radius of bend in the routing of the cable to a minimum.
- 4) Assemblies over 6 feet should be supported at various points along the length of the conduit to minimize vibration induced failures at the conduit/fitting junction.

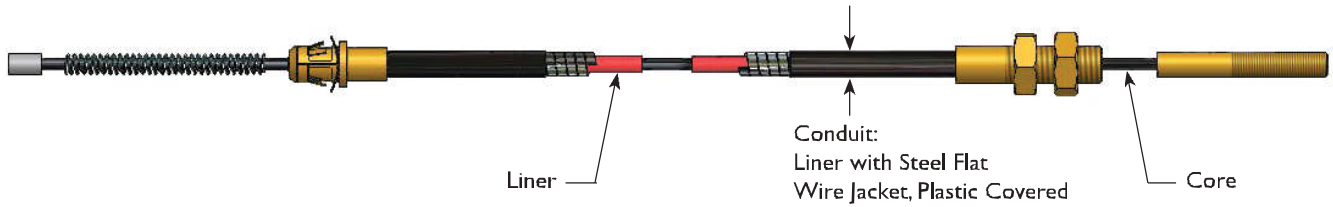

**WESCON**®

**.125 Dia. Series Brake Cables**

Minimum bend radius: 5 inches  
 Proof loaded 100% to 1200 lbs.

	Conduit		Core
	Cover	Liner	
<b>Standard</b>	H.D.PE.*	H.D	.125 (1/8) Dia-1x19 Galvanized Cable Nylon Covered to .156 (5/32) Dia
<b>Premium **</b>	Nylon	Nylon	

**WESCON**®

**.156 Dia. Series Brake Cables**

Minimum bend radius: 6 inches  
 Proof loaded 100% to 1800 lbs.

	Conduit		Core
	Cover	Liner	
<b>Standard</b>	H.D.PE.*	H.D.PE.*	.156 (5/32) Dia-1x19 Galvanized Cable Nylon Covered to .187 (3/16) Dia

**WESCON**®

**.187 Dia. Series Brake Cables**

Minimum bend radius: 7 inches  
 Proof loaded 100% to 2400 lbs.

	Conduit		Core
	Cover	Liner	
<b>Standard</b>	H.D.PE.*	H.D E.*	.187 (3/16) Dia-1x37 Galvanized Cable

\* H.D.P.E. = High Density Polyethylene

\*\* For Applications up to 300° F

Fill in your requirements and fax to **Wescon** at **316-942-5114**  
 or visit our web-site **www.w** **.com**

Company Name: \_\_\_\_\_ Contact Person: \_\_\_\_\_

Phone : \_\_\_\_\_ Fax: \_\_\_\_\_ E-Mail: \_\_\_\_\_

Which Cable Series Fits your Application? (See page 4)  .125 Series  .156 Series  .187 Series

Which Type?  Standard  Premium

Will cable be used with a brake le \_\_\_\_\_ If Yes, model number (See pages 11-19 & 22-28) \_\_\_\_\_

What will be your Part Number? Cable Assy \_\_\_\_\_ Brake Lever \_\_\_\_\_

Optional Accessories? (See page 7)  Jam Nut  Retaining Ring  Compression Spring  Boots

<b>Cable Fitting Part No.</b>	<b>Conduit Fitting Part No.</b>	<b>Conduit Fitting Part No.</b>	<b>Cable Fitting Part No.</b>

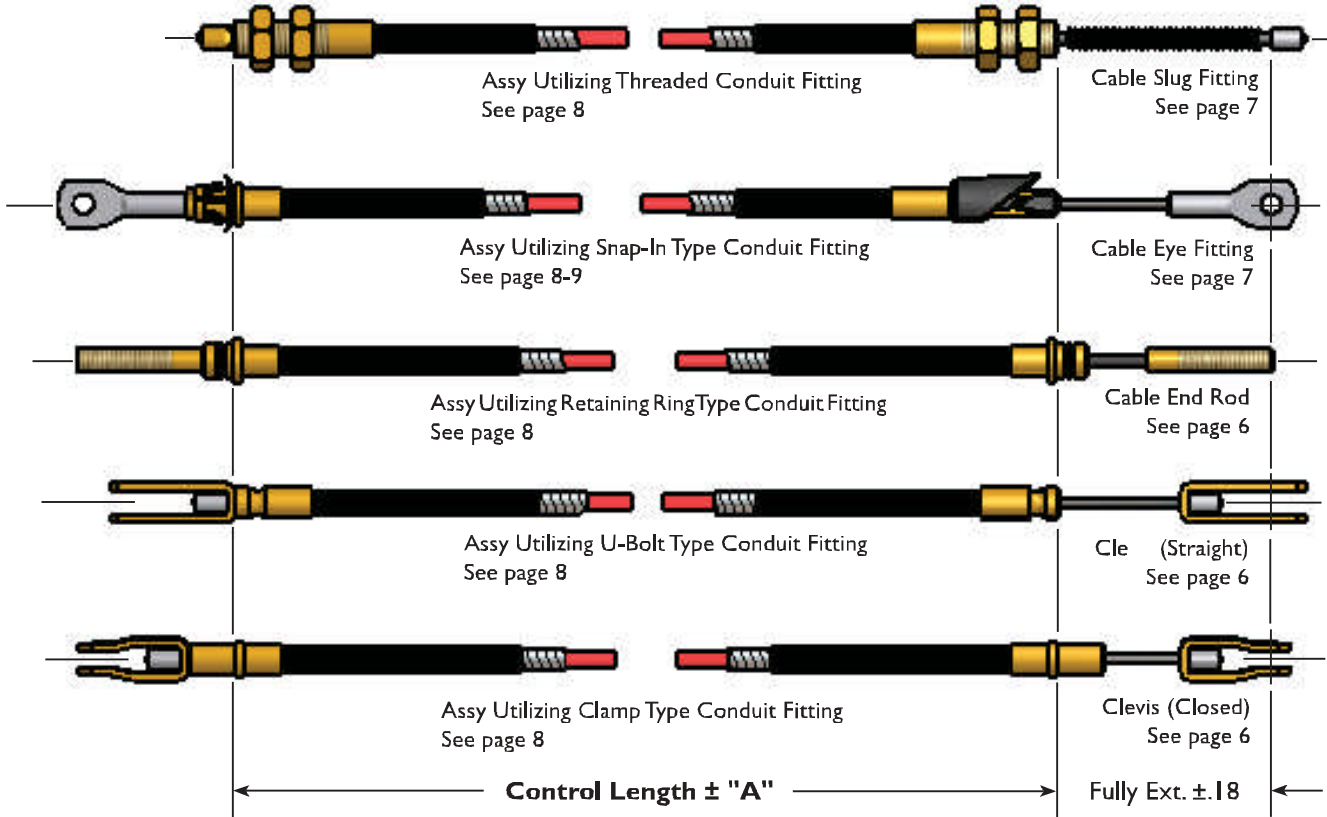

Control Length (Inches)	"A"
Up to 24.00	± .12
24.01 to 60.00	± .18
60.01 to 120.00	± .25
120.01 to 240.00	± .50
Above 240.00	± 1.00

**Cle (Closed) .125/.156/.187 Series**

Part Number	Type	"A"	"B"	"C"	"D"	Cable End Type	Cle
-2121-01	I	.21/.27	.41/.42	1.44	.65	Slug Fitting	5/16
22-2121-04	I	.22/.28	.51/.52	2.38	.75	5/16 Dia Thd. Rod	5/16
22-2121-05	I	.22/.28	.51/.52	1.75	.75	5/16 Dia Thd. Rod	3/8
22-2121-06	I	.16/.22	.51/.52	1.88	.75	5/16 Dia Thd. Rod	5/16
22-2121-07	I	.22/.28	.38/.39	1.88	.75	Slug Fitting	3/8
22-2121-08	I	.16/.22	.38/.39	1.56	.75	Slug Fitting	3/8
22-2121-09	I	.22/.28	.51/.52	1.75	.75	Slug Fitting	5/16
22-2121-10	I	.20/.28	.51/.52	2.38	.75	Slug Fitting	3/8
22-2121-11	I	.26/.28	.51/.52	1.45	.75	Slug Fitting	5/16
22-2121-13	II	.21/.27	.41/.42	1.44	.65	Slug Fitting	5/16
22-2121-14	I	.28/.34	.51/.52	2.38	.75	Slug Fitting	3/8
22-2121-16	I	.25/.29	.41/.42	1.44	.65	Slug Fitting	1/4

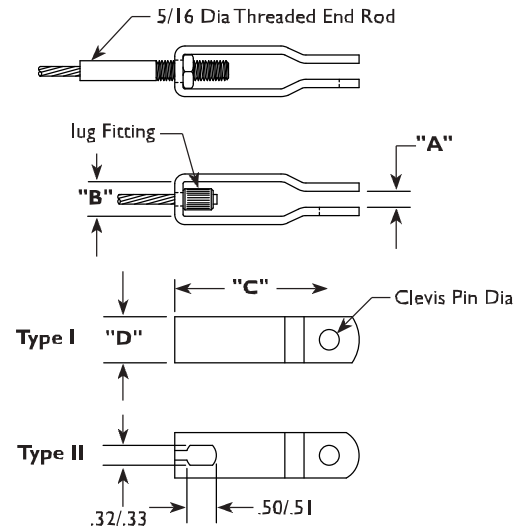

**Cle (Straight) .125/.156/.187 Series**

Part Number	"A"	"B"	"C"	"D"	Cable End Type	Cle
-2122-01	.38/.45	.39/.40	1.62	.62	Slug Fitting	5/16
22-2122-02	.38/.45	.39/.40	2.00	.62	Slug Fitting	5/16
22-2122-07	.49/.56	.51/.52	1.62	.62	Slug Fitting	5/16
22-2122-08	.49/.56	.51/.52	1.94	.75	Slug Fitting	3/8
22-2122-09	.49/.56	.51/.52	2.50	.75	5/16 Dia Thd. Rod	5/16
22-2122-10	.49/.56	.51/.52	2.50	.75	5/16 Dia Thd. Rod	3/8
22-2122-11	.49/.56	.51/.52	1.94	.75	Slug Fitting	5/16
22-2122-18	.49/.56	.51/.52	1.94	.75	Slug Fitting	1/2
22-2122-19	.55/.59	.57/.58	.94	.75	Slug Fitting	1/2
22-2122-21	.49/.56	.51/.52	1.62	.62	5/16 Dia Thd. Rod	5/16
22-2122-26	.65/.69	.63/.67	.68	.62	Slug Fitting	5/16
22-2122-27	.71/.79	.72/.75	1.94	.75	Slug Fitting	3/8

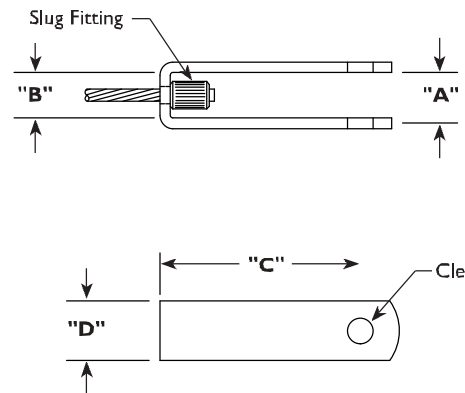

**Thr End Rod**

.125 Series				
Part Number	Core Size	"A"	"B"	Thread
21-1052-47	.125 Dia	2.62	1.50	3/8-24 UNF-2A
21-1052-11	.125 Dia	3.62	2.25	5/16-24 UNF-2A
21-1052-12	.125 Dia	4.62	3.25	5/16-24 UNF-2A
21-1052-13	.125 Dia	2.75	1.50	1/4-28 UNF-2A
21-1052-14	.125 Dia	2.50	1.50	5/16-24 UNF-2A
21-1052-20	.125 Dia	5.00	2.50	1/4-20 UNC-2A
.156 Series				
Part Number	Core Size	"A"	"B"	Thread
21-1052-26	.156 Dia	2.00	1.00	3/8-24 UNF-2A
21-1052-27	.156 Dia	2.50	1.50	3/8-24 UNF-2A
21-1052-28	.156 Dia	3.00	2.00	3/8-24 UNF-2A
21-1052-29	.156 Dia	3.25	2.25	3/8-24 UNF-2A

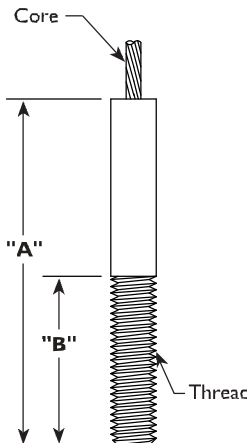

.187 Series				
Part Number	Core Size	"A"	"B"	Thread
21-1052-35	.187 Dia	2.00	1.00	3/8-24 UNF-2A
21-1052-36	.187 Dia	2.50	1.50	3/8-24 UNF-2A
21-1052-37	.187 Dia	3.00	2.00	3/8-24 UNF-2A
21-1052-38	.187 Dia	3.25	2.25	3/8-24 UNF-2A
21-1052-39	.187 Dia	2.00	1.00	5/16-24 UNF-2A
21-1052-40	.187 Dia	2.50	1.50	5/16-24 UNF-2A
21-1052-41	.187 Dia	3.25	2.25	5/16-24 UNF-2A
21-1052-42	.187 Dia	4.00	3.00	5/16-24 UNF-2A
21-1052-31	.156 Dia	2.50	1.50	5/16-24 UNF-2A
21-1052-32	.156 Dia	3.25	2.25	5/16-24 UNF-2A

Cable Ey Fitting

.125 Series				
Part Number	Core Size	"A"	"B"	"C"
21-1108-13	.125 Dia	.500	1.93	.75
21-1108-18	.125 Dia	.329	1.93	.75
21-1108-19	.125 Dia	.329	1.50	.75
21-1108-24	.125 Dia	.475	1.50	.75
.156 Series				
Part Number	Core Size	"A"	"B"	"C"
21-1108-17	.156 Dia	.500	1.93	.75
21-1108-28	.156 Dia	.323	1.93	.56
21-1108-29	.156 Dia	.386	1.93	.75
.187 Series				
Part Number	Core Size	"A"	"B"	"C"
21-1108-06	.187 Dia	.265	1.93	.75
21-1108-07	.187 Dia	.329	1.93	.75
21-1108-08	.187 Dia	.386	1.93	.75

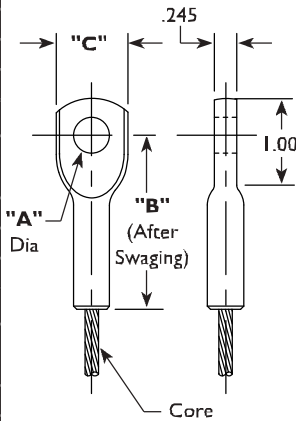

Cable Swage Fitting

.125 Dia Bare/Covered Cable				
Part Number	Core Size	"A"	"B" Dia (Approx.)	Type
21-1086-28	.125 Dia	.50	5/16	VI
21-1086-30	.125 Dia	.50	3/8	VII
21-1086-37	.125 Dia	.50	3/8	VI
21-1086-50	.125 Dia	1.28	11/32	IV
.156 Dia Bare Cable				
Part Number	Core Size	"A"	"B" Dia (Approx.)	Type
21-1086-39	.156 Dia	.87	3/8	VI
.187 Dia Bare Cable				
Part Number	Core Size	"A"	"B" Dia (Approx.)	Type
21-1086-05	.187 Dia	.87	3/8	I
21-1086-35	.187 Dia	.87	3/8	III

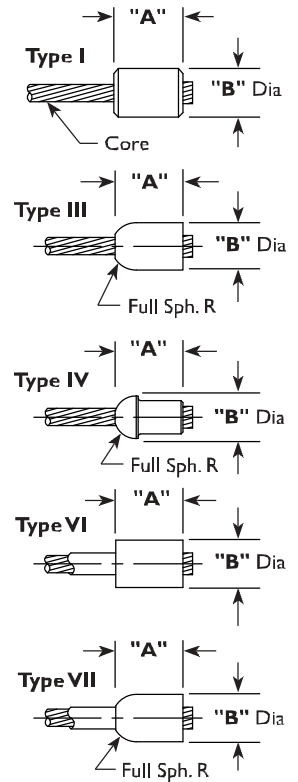

Jam Nut

.125 and .187 Series	
Part Number	
80-0006-72	

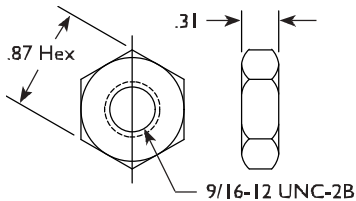

Retaining Ring

.125 and .187 Series	
Part Number	
80-0033-09	

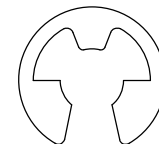

NOTE: Use with Retaining Ring Conduit Fitting (See page 8)

Compression Spring

(26-6332 Series)

Many standard springs are available for your application. Contact Wescon for details.

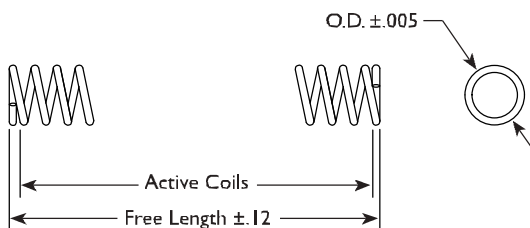

Flexible Boot - Ethylene Propylene (EPDM)

(03-0003 Series)

For additional protection and in severe applications, where moisture and debris are major concerns, flexible boots are available to prevent foreign materials and moisture from entering the cable, providing superior performance and longer life.

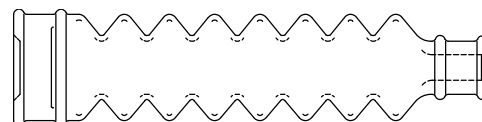

**Retaining Ring Conduit Fitting**

**.125 Series**  
**21-2404-02, -07**  
 Standard Fitting

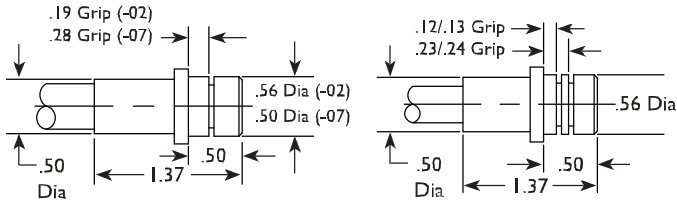

**21-2404-01**  
 Standard Fitting

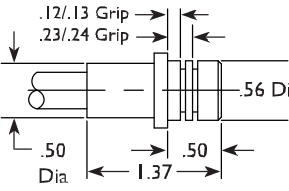

**.156/.187 Series**  
**21-2404-05, -06**  
 Standard Fitting

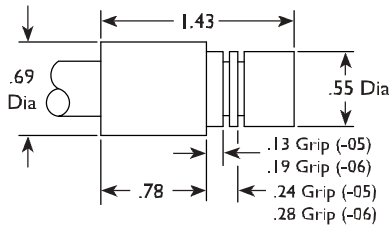

**Retaining Ring / Boot Conduit Fitting**

**.125 Series**  
**21-2404-15**  
 Standard Fitting

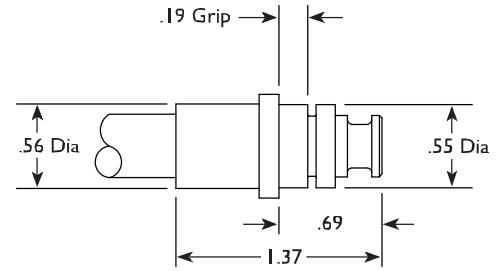

**.156/.187 Series**  
**21-2404-11**  
 Standard Fitting

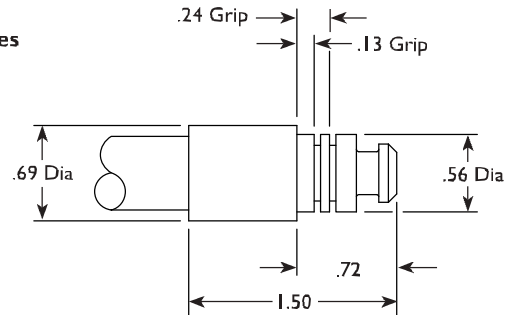

**U-Bolt Conduit Fitting**

**.125 Series**  
**21-2410-01**  
 Standard Fitting

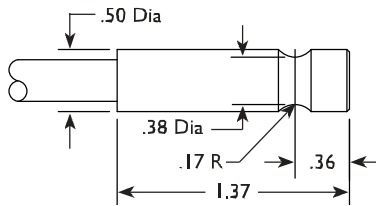

**.156/.187 Series**  
**21-2410-02**  
 Standard Fitting

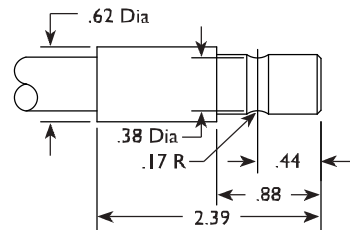

**Clamp Type Conduit Fitting**

**.125 Series**  
**21-2406-01**  
 Standard Fitting

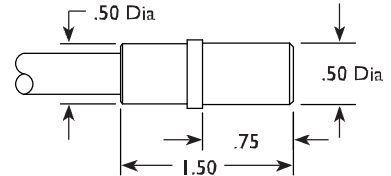

**.156/.187 Series**  
**21-2406-03**  
 Standard Fitting

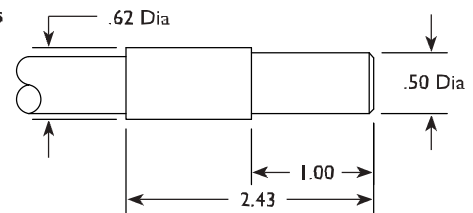

**38° Conduit Fitting**

**.125 Series**

**18-0034-01**  
 10" Backing Plate

**18-0034-02**  
 12" Backing Plate

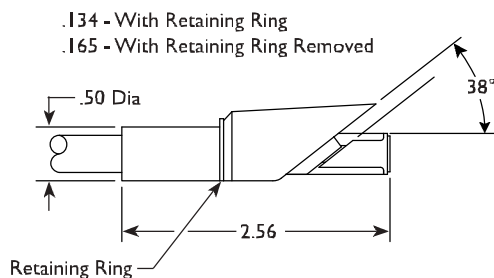

**Threaded Conduit Fitting**

.125 Series			
Part Number	"A"	"B"	"C"
21-2405-01	2.37	1.50	.56 Dia
.156/.187 Series			
Part Number	"A"	"B"	"C"
21-2405-02	2.43	1.50	.62 Dia
21-2405-03	2.93	2.00	.62 Dia

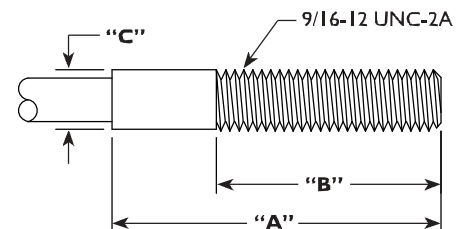



Snap-In Conduit Fitting

**.125 Series**  
**18-0014-07**  
 .12/.18 Grip  
 .57/.58 Dia Mounting Hole

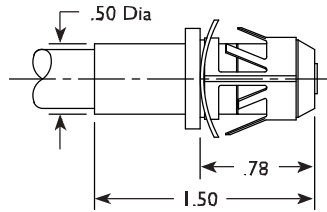

**.125 Series**  
**18-0024-01**  
 .12/.18 Grip  
 .62 Dia Mounting Hole

**.156/.187 Series**  
**18-0024-02**  
 .12/.18 Grip  
 .57/.58 Dia Mounting Hole

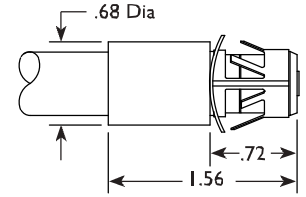

**.156/.187 Series**  
**18-0024-03**  
 .12/.18 Grip  
 .62 Dia Mounting Hole

Equalizer  
 Part Number - 02-1600-89

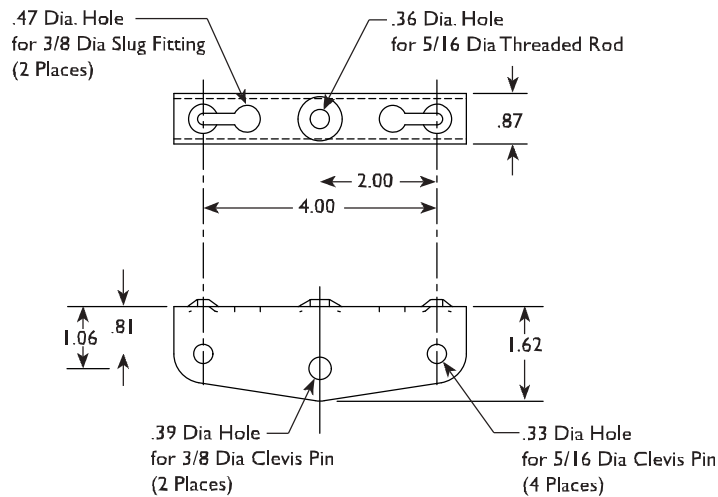

Typical Applications and Recommended Components

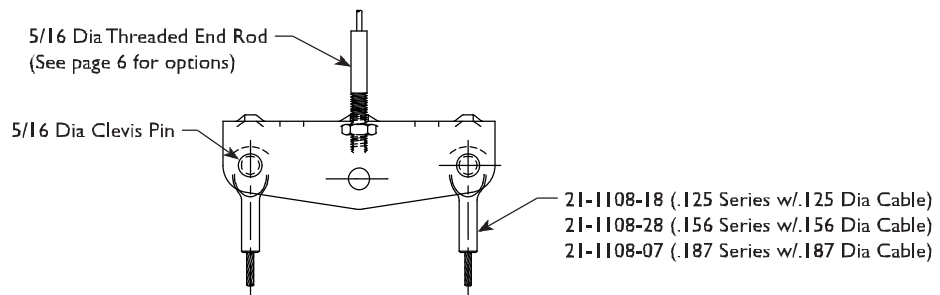
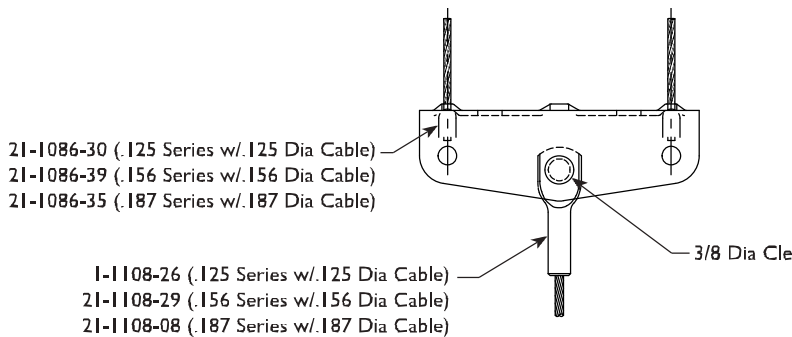



**Flange Mount Brake Lever with Single Cable**  
**Model 202 (Pg. 13), Model 206 (Pg. 17),**  
**Model 208 (Pg. 19)**



**Flange Mount Brake Le** **I Cable**  
**Model 205 (Pg. 16)**



**Side Mount Brake Lever with Single Cable**  
**Model 200 (Pg. 11), Model 201(Pg. 12),**  
**Model 203 (Pg. 14), Model 207 (Pg. 18)**



**Side Mount Brake Lever with Dual Cable**  
**Model 204 (Pg. 15)**

## Over-Center Brake Lever Part Number Codes

For Over-Center Brake Levers Shown on Pages 11-19

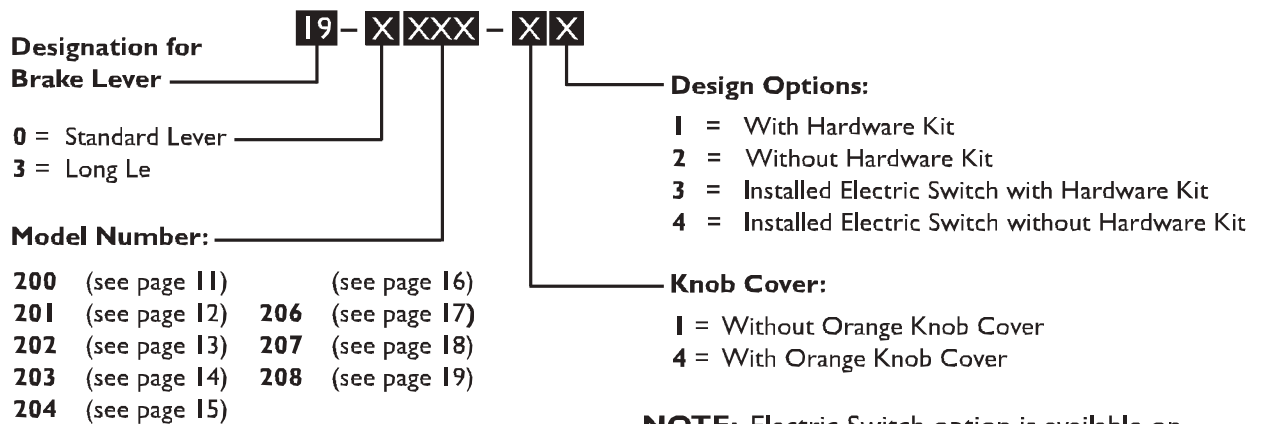

**NOTE:** Electric Switch option is available on all over-center brake le

## Typical Applications and Features

All dimensions are inches (mm)

- Side mount to cowling, instrument panel, seat riser or frame installation

- Use clamp-t

le that attaches to the brake lever:

- 2.5 inches (64mm) wide side plates with three alternate positions for attaching one brake cable assembly.

- Electric switch option (See page 30)

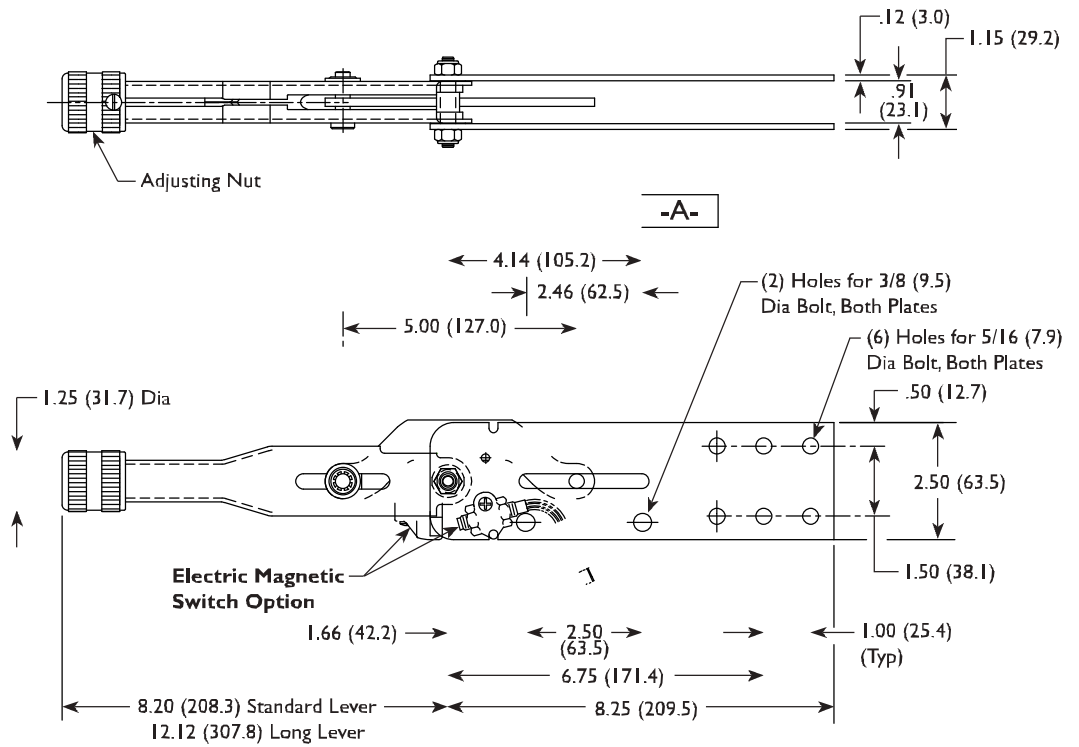

## 01-5001-23 Hardware Kit

(Items listed in parentheses not included in kit)

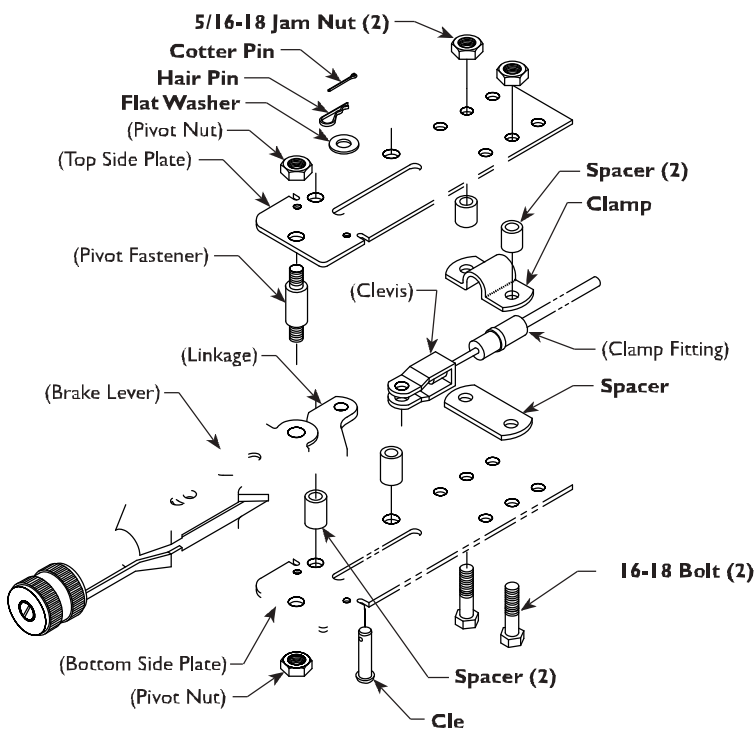

## Recommended components for mounting brake cable with this brake lever

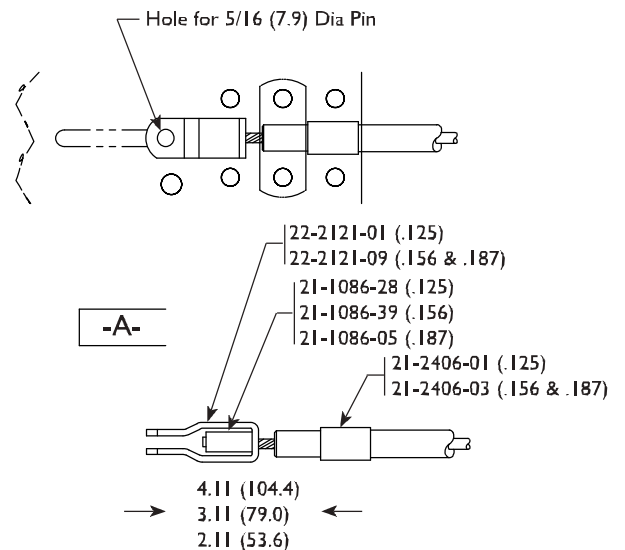

### NOTE:

Dimensions 3.11 and 4.11 depict lengths when lever is in "OFF" position. The 2.11 dimension will not allow the lever to be put in full "OFF" position. This will reduce the net travel of the lever. These dimensions should be used to calculate cable assembly length.



## Typical Applications and Features

All dimensions are inches (mm)

- Flange mount for bulkhead, floor or island (dog house) installation.
- Use clamp-t  
) on the end of the cable that attaches to the brake lever.
- 2.5 inches (64mm) wide side plate assembly.
- The rigid frame maintains alignment of clevis pin guideslots for improved life of both the pin and side plate assembly.

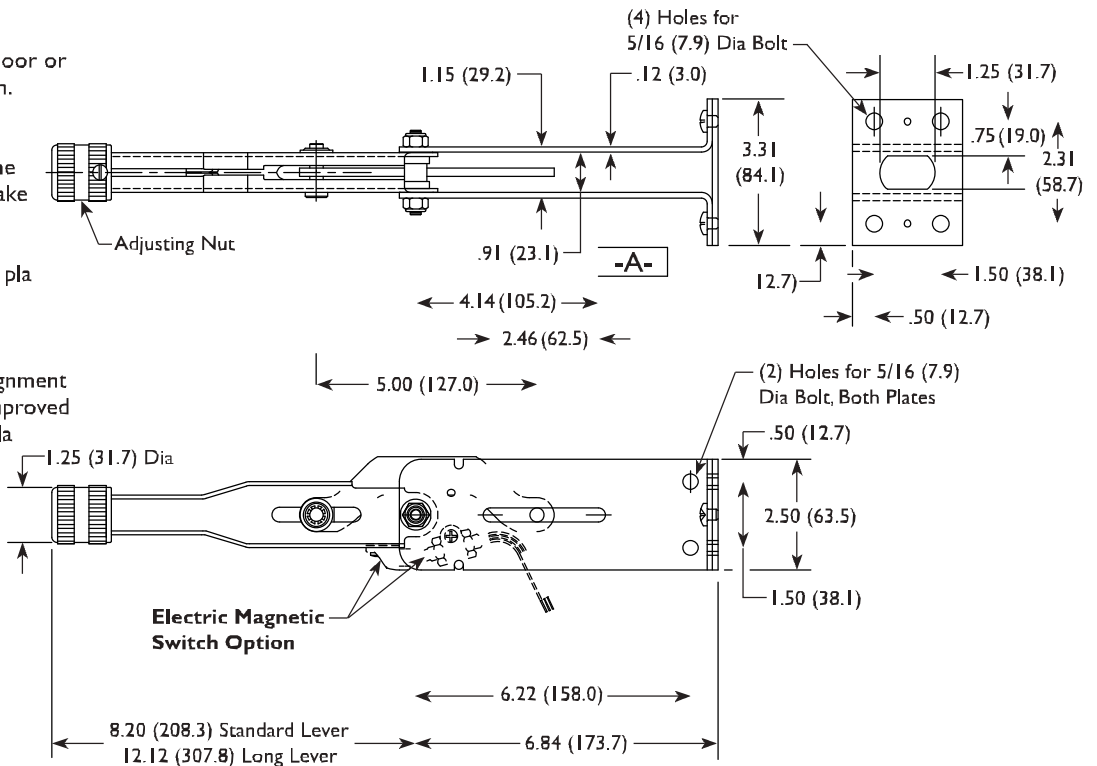

Electric Switch Option  
(See page 30)

### 01-5001-01 Hardware Kit (Items Listed in Parentheses not included in Kit)

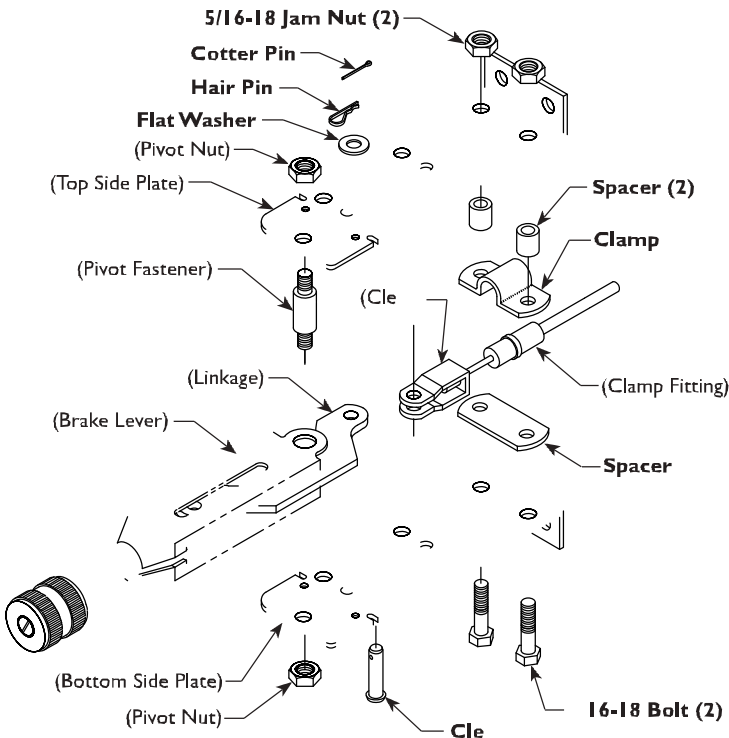

### Recommended components for mounting brake cable with this brake lever assembly

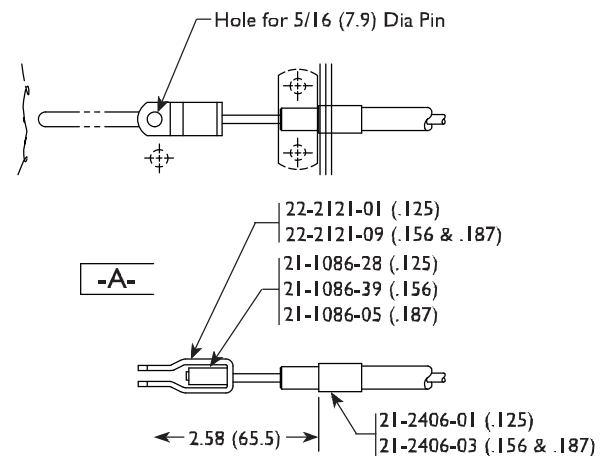

#### NOTE:

Dimension 2.58 (65.5) depicts length when lever is in "OFF" position. These dimensions should be used to calculate cable assembly length.



## Typical Applications and Features

All dimensions are inches (mm)

- Side mount to cowling, instrument panel, seat riser or frame installation.
- Use clamp-t (See page 8) on the end of the cable that attaches to the brake le

1.5 inches (38mm) wide side plates with single position for attaching one brake cable assembly.

- Electric Switch Option (See page 30)

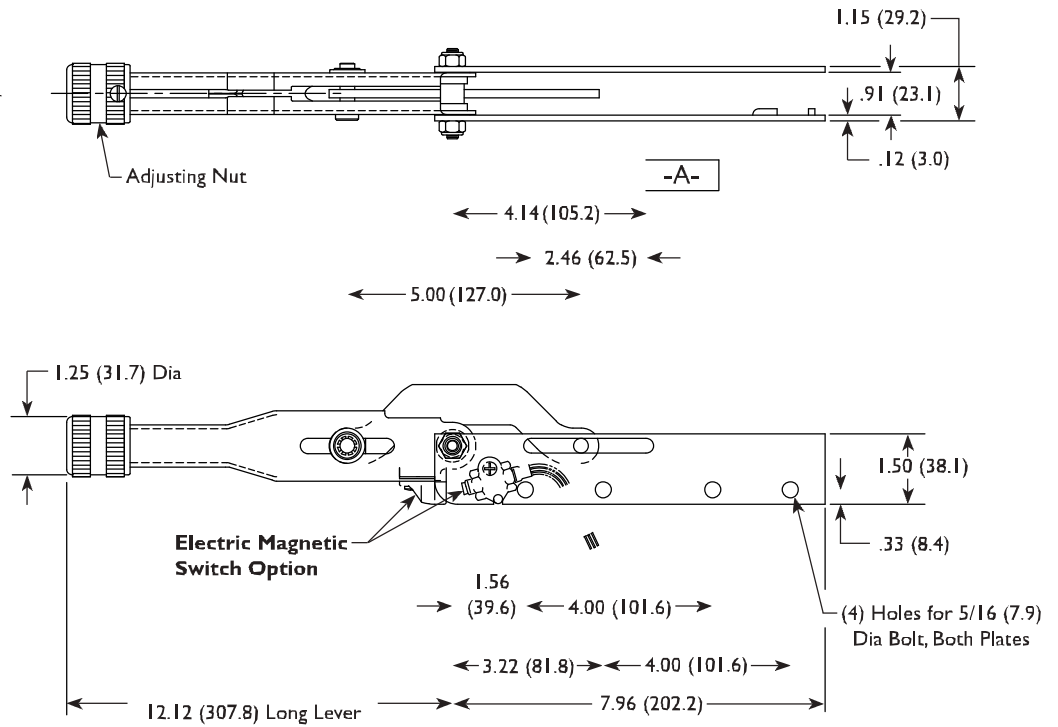

### 01-5001-100 Hardware Kit (Items listed in parentheses not included in kit)

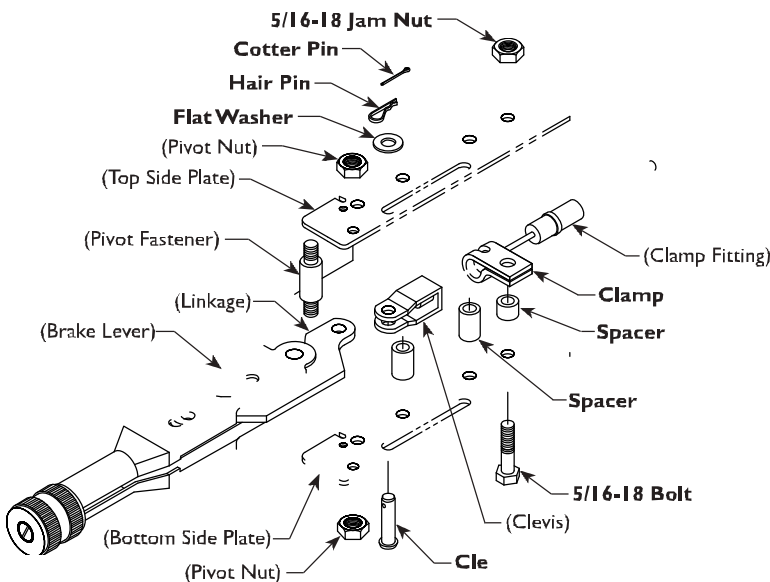

### Recommended components for mounting brake cable with this brake le ly

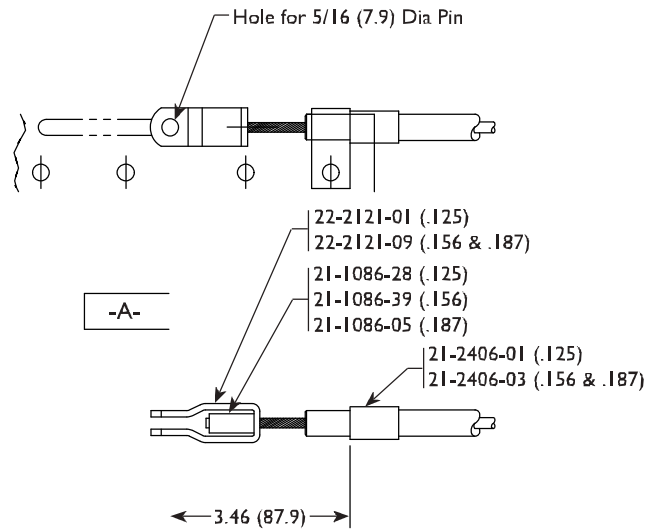

**NOTE:**

Dimension 3.46 (87.9) depicts length when lever is in "OFF" position. These dimensions are used to calculate cable assembly length.

## Typical Applications and Features

All dimensions are inches (mm)

- Side mount to cowling, instrument panel, seat riser or frame installation.
- Use clamp-t ( ) on the end of the cable that attaches to the brake le
- 2.5 inches (64mm) wide side pla le position for attaching two brake cable assemblies.
- When considering load requirements, the load on the lever assembly will be the sum of the load in each cable.
- Electric Switch Option (See page 30)

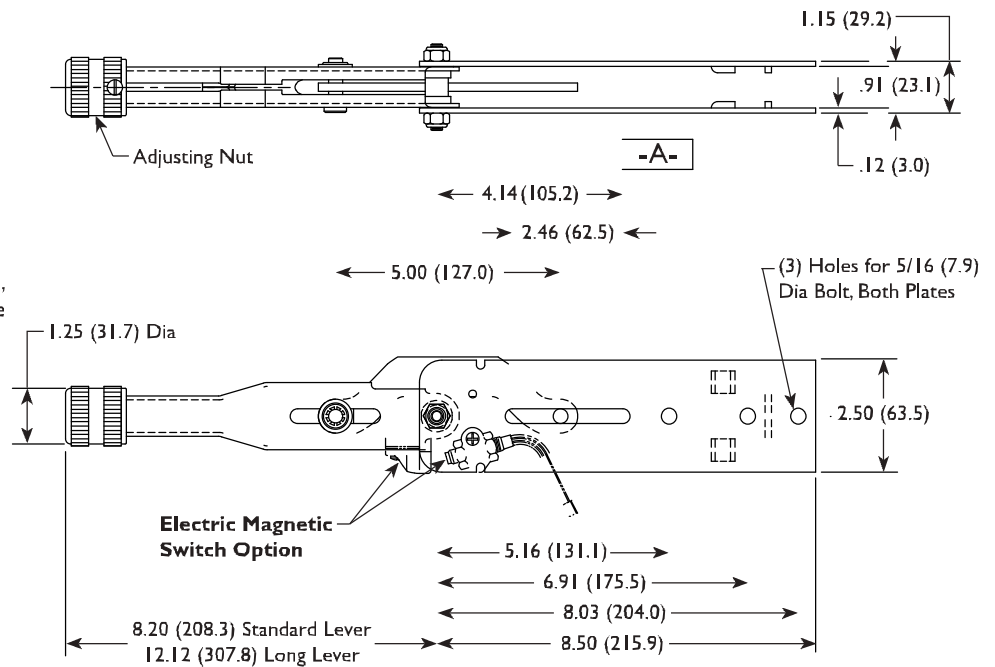

### 01-5001-99 Hardware Kit (Items listed in parentheses not included in kit)

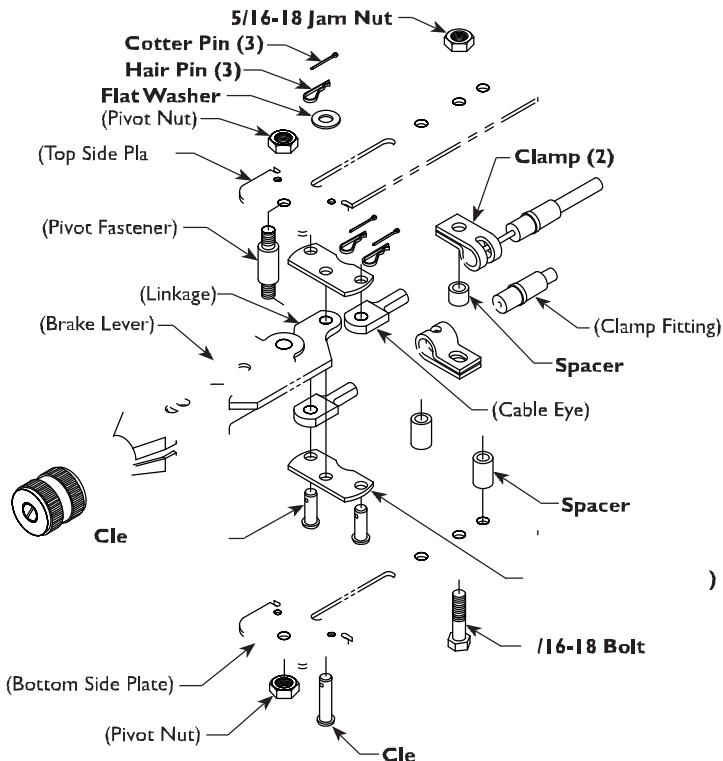

### Recommended components for mounting brake cable with this brake le ly

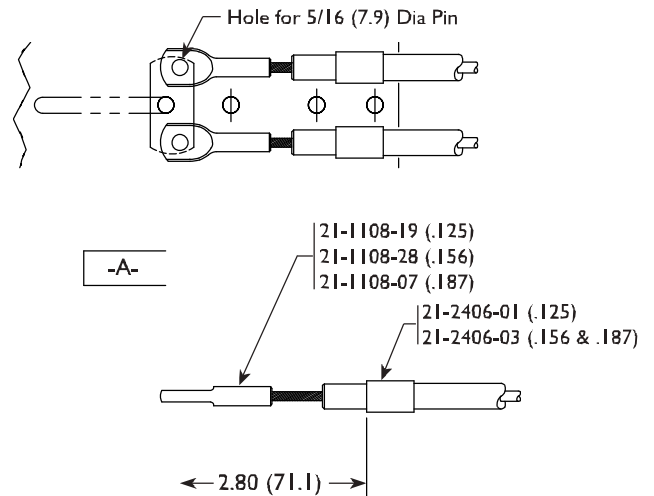

### NOTE:

Dimension 2.80 (71.1) depicts length when le F position. These dimensions are used to calculate cable assembly length.

## Typical Applications and Features

All dimensions are inches (mm)

- Flange mount for bulkhead, floor or island (dog house) installation.

- Use clamp-t

le that attaches to the brake lever:

- 2.5 inches (64mm) wide side plates with single position for attaching two brake cable assemblies.

- When considering load requirements, the load on the lever assembly will be the sum of the load in each cable.

- Electric Switch Option (See page 30)

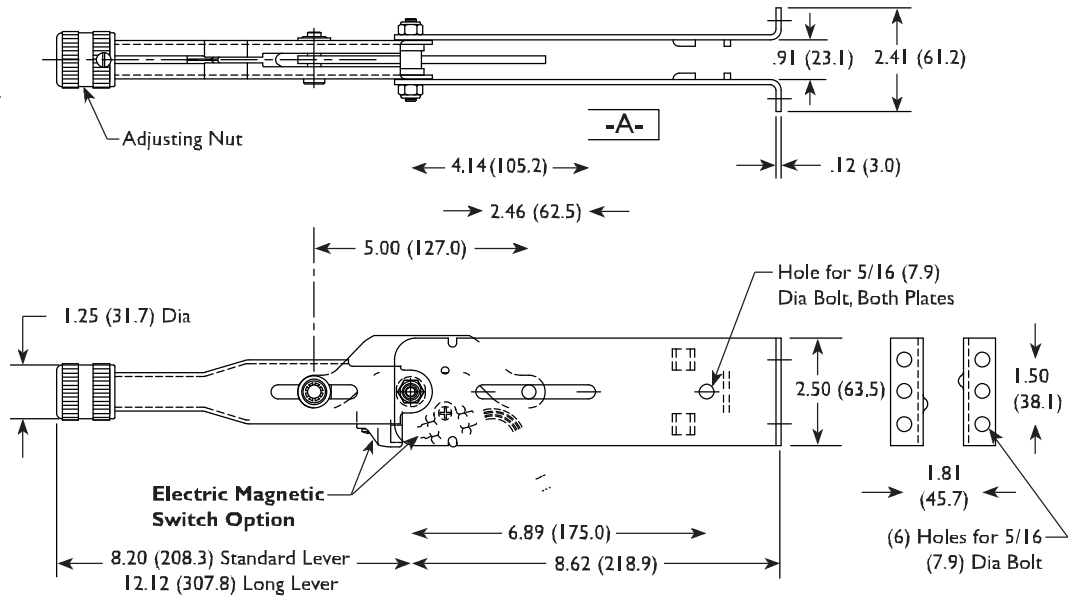

### 01-5001-05 Hardware Kit (Items listed in parentheses not included in kit)

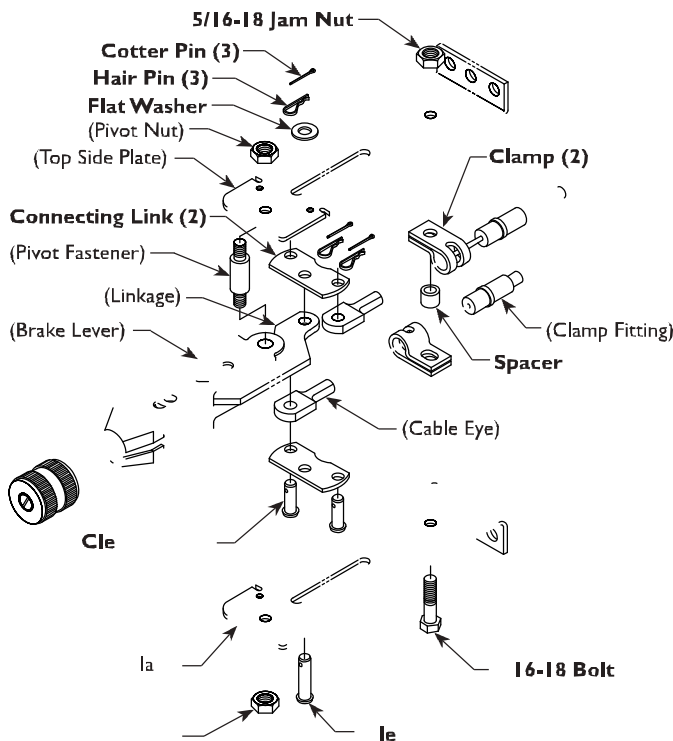

### Recommended components for mounting brake cable with this brake lever

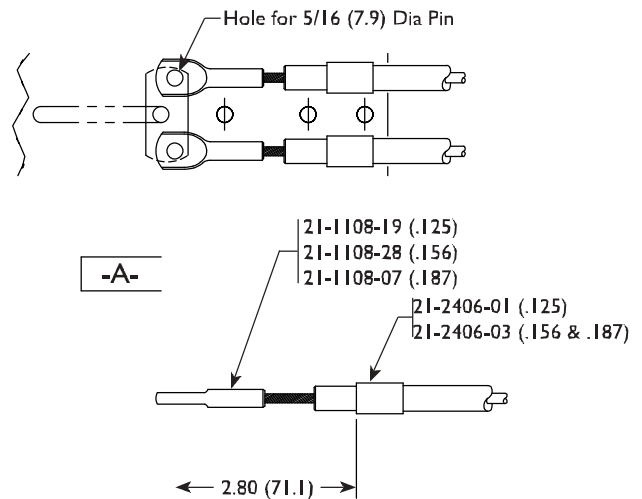

#### NOTE:

Dimension 2.80 (71.1) depicts length when lever is in "OFF" position. These dimensions are used to calculate cable assembly length.

## Typical Applications and Features

All dimensions are inches (mm)

- Flange mount for bulkhead, floor or island (dog house) installation.
- Use clamp-t (See page 8) on the end of the cable that attaches to the brake le
- 2.5 inches (64mm) wide side pla le position for attaching one brake cable assembly.
- Electric Switch Option (See page 30)

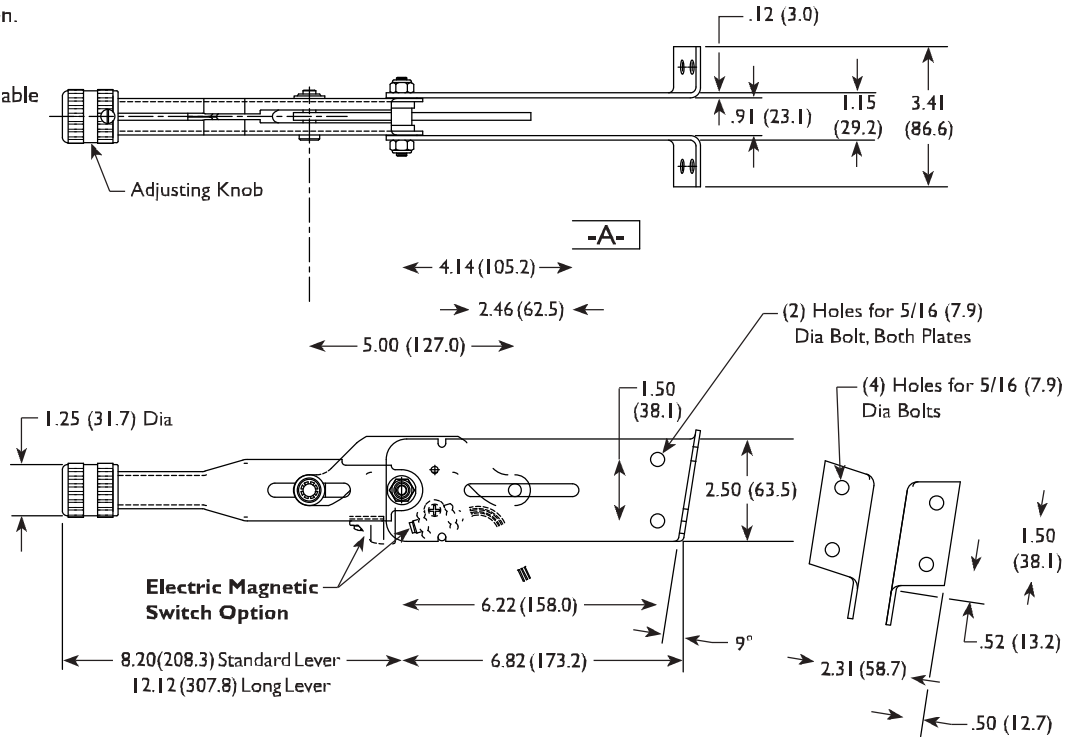

### 01-5001-03 Hardware Kit (Items listed in parentheses not included in kit)

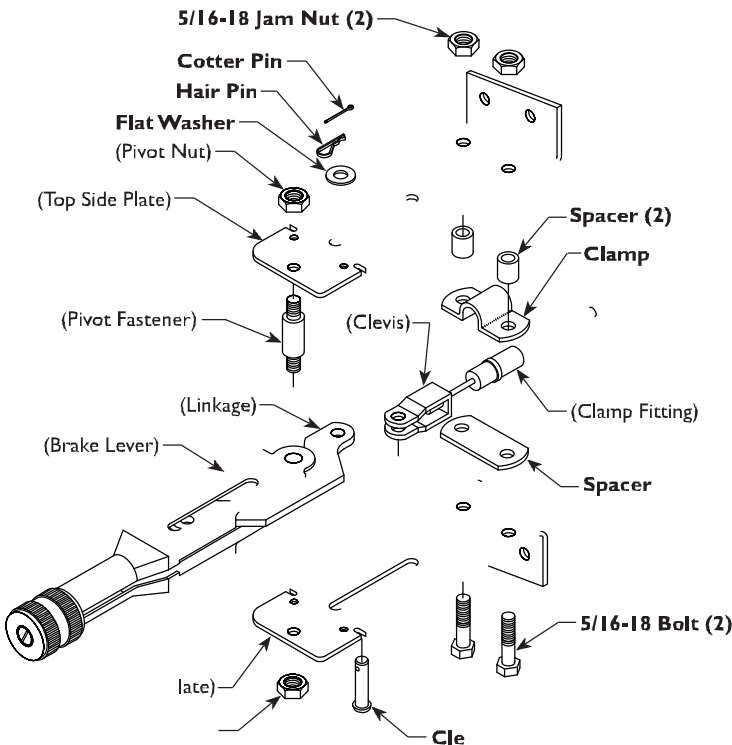

### Recommended components for mounting brake cable with this brake le ly

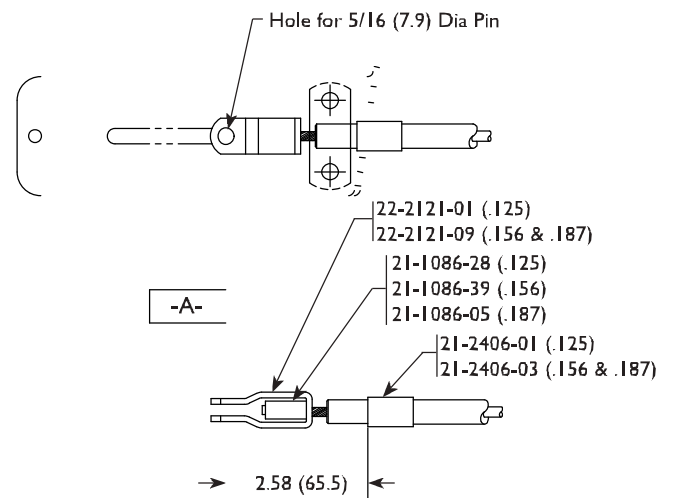

### NOTE:

Dimension 2.58 (65.5) depicts length when lever is in "OFF" position. These dimensions are used to calculate cable assembly length.

## Typical Applications and Features

All dimensions are inches (mm)

- Side mount to cowling, instrument panel, seat riser or frame installation
- Use snap-in type conduit fittings (See page 8-9) on the end of the cable that attaches to the brake lever.
- 1.5 inches (38mm) wide side plate position for attaching one brake cable assembly.
- Electric Switch Option (See page 30)

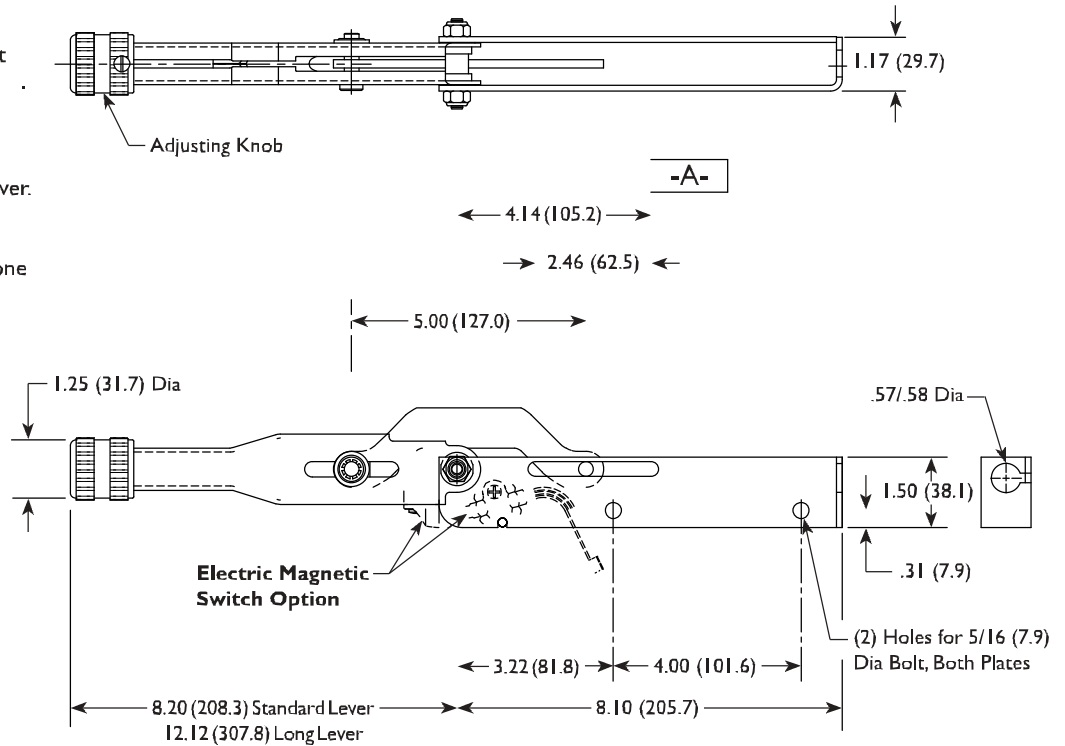

### 01-5001-04 Hardware Kit (Items listed in parentheses not included in kit)

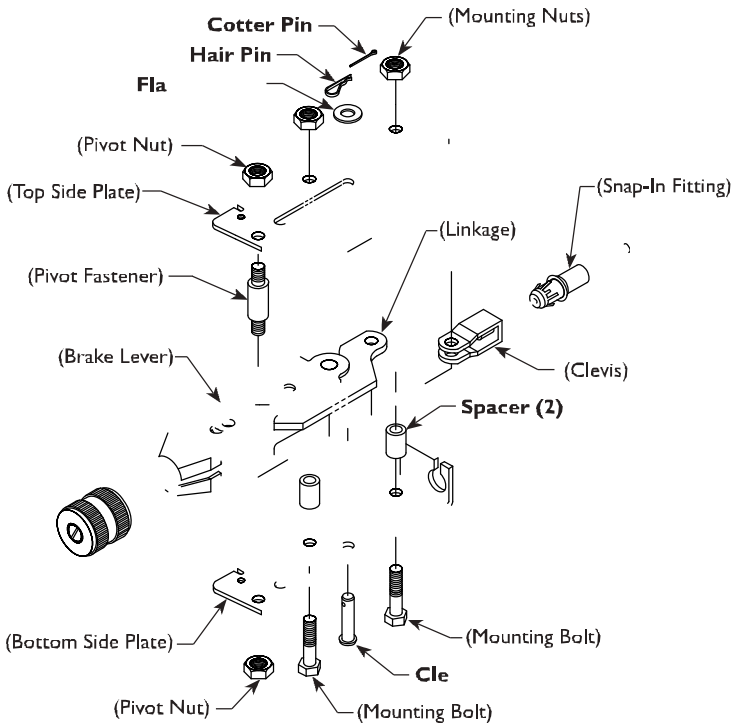

### Recommended components for mounting brake cable with this brake lever

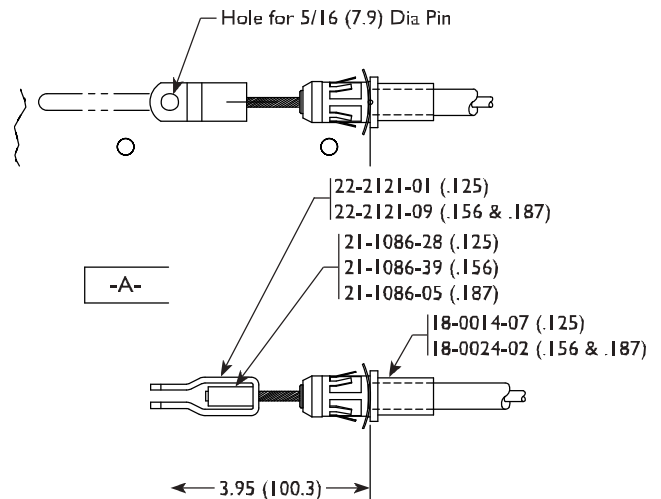

#### NOTE:

Dimension 3.95 (100.3) depicts length when lever is in "F" position. These dimensions are used to calculate cable assembly length.



## Typical Applications and Features

All dimension are inch (mm)

- Flange mount for bulkhead, floor or island (doghouse) installation.
- Use clamp-t (See page 8) on the end of the cable that attaches to the brake lever.
- 2.5 inches (64mm) wide side plate position for attaching one brake cable assembly.
- Electric Switch Option (See page 30)

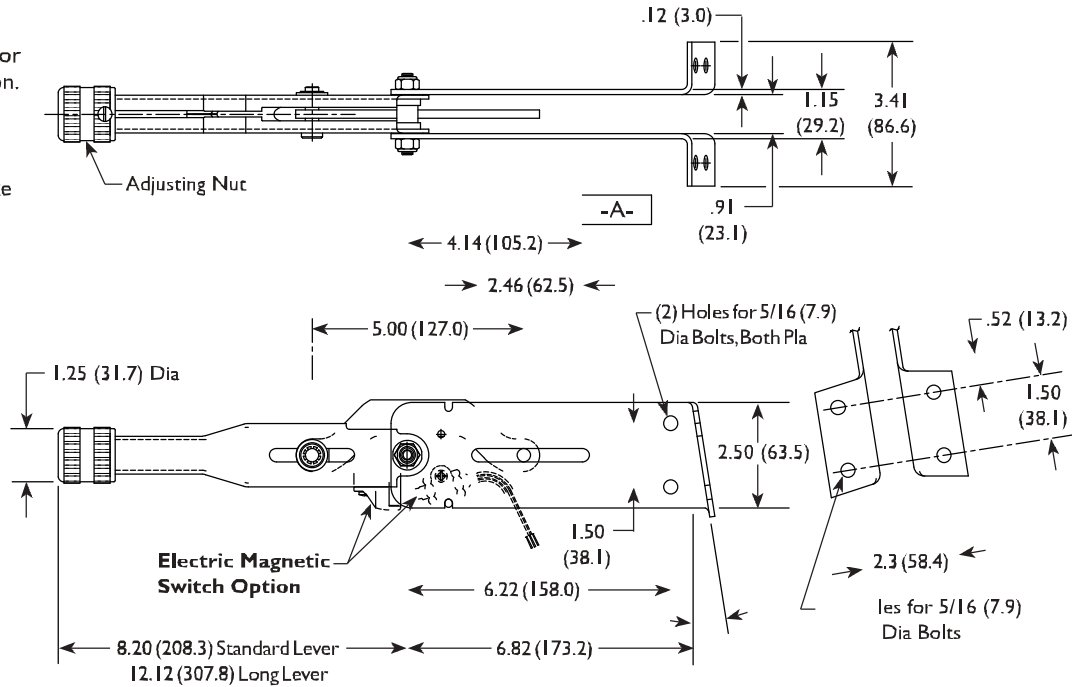

### 01-5001-02 Hardware Kit

(Items listed in parentheses not included in kit)

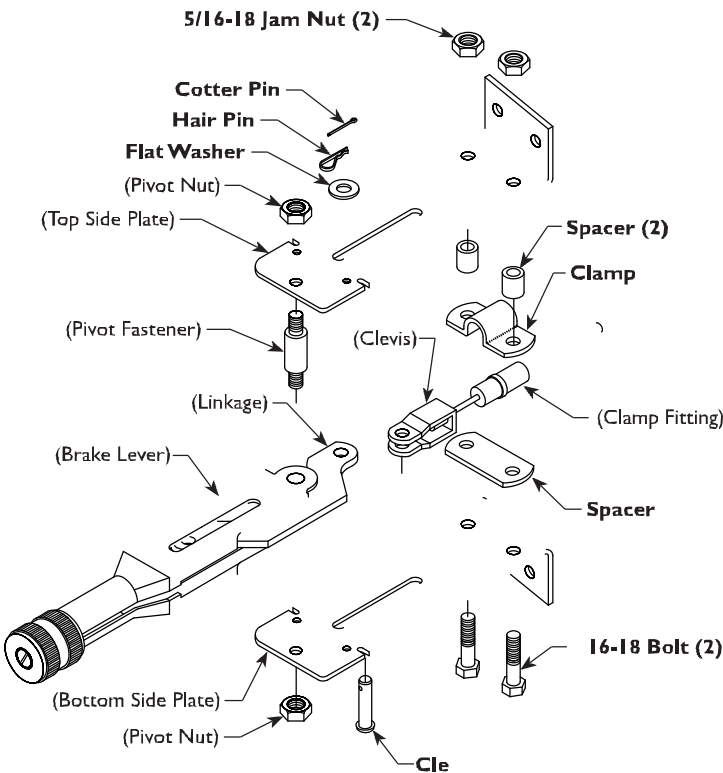

### Recommended components for mounting brake cable with this brake lever

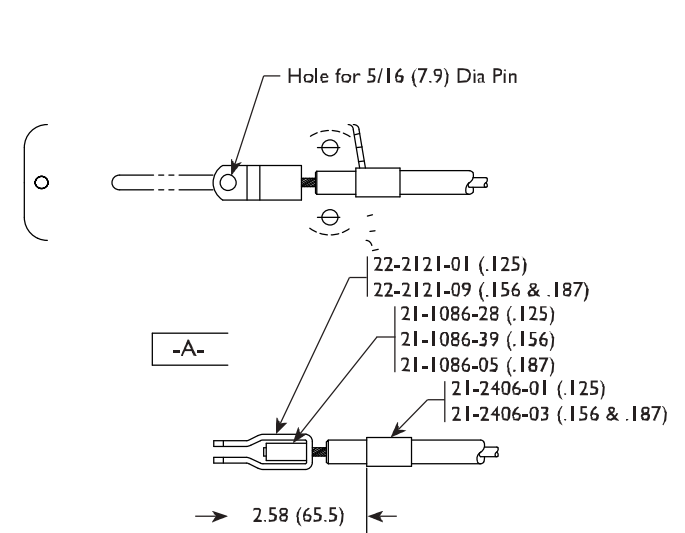

### NOTE:

Dimension 2.58 (65.5) depicts length when lever is in the "FF" position. These dimensions are used to calculate cable assembly length.

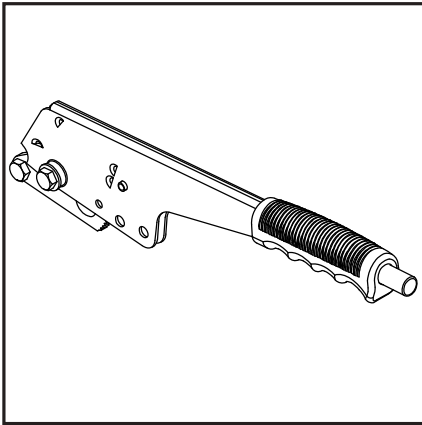

**Model 302** (Page 22)

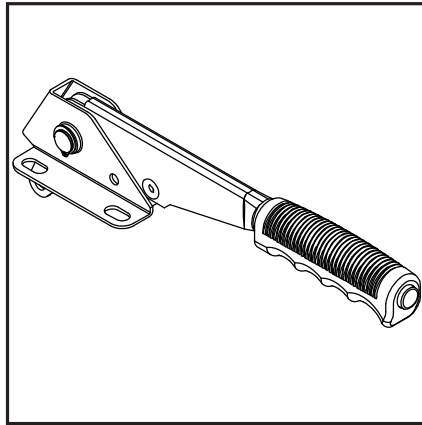

**Model 316** (Page 23)

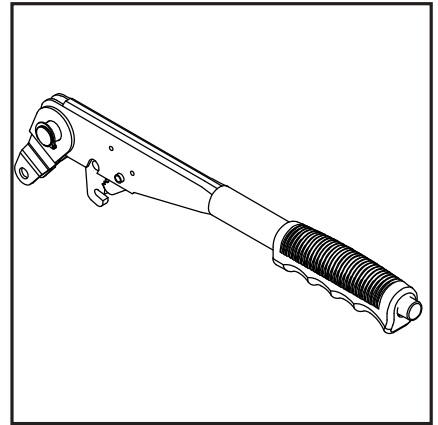

**Model 320** (Page 24)

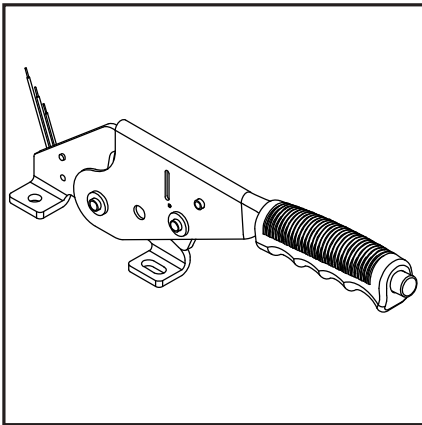

**Model 330** (Page 25)

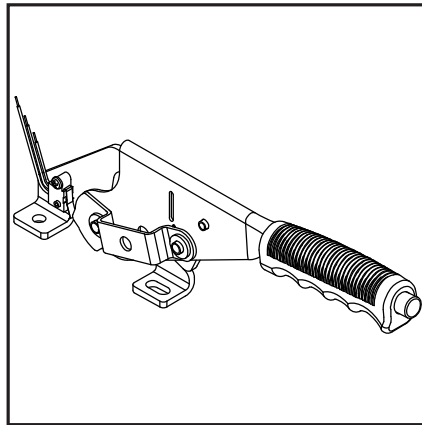

**Model 335** (Page 26)

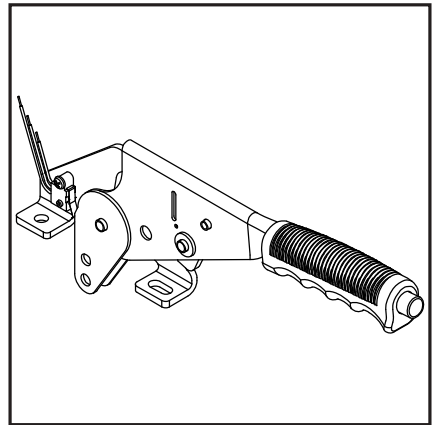

**Model 340** (Page 27)

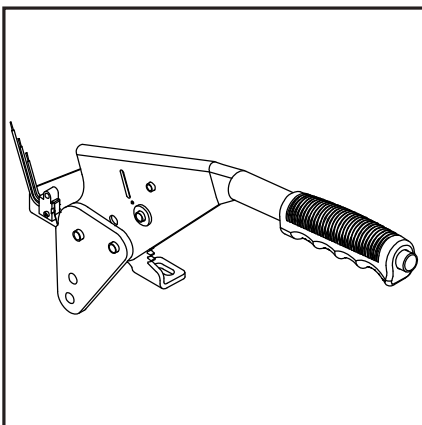

**Model 360** (Page 28)

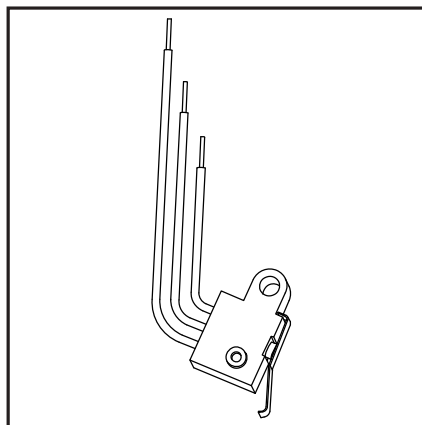

**Accessories** (Page 29)

## Ratcheting Brake Lever Part Number Codes

For Ratcheting Brake Le

-28

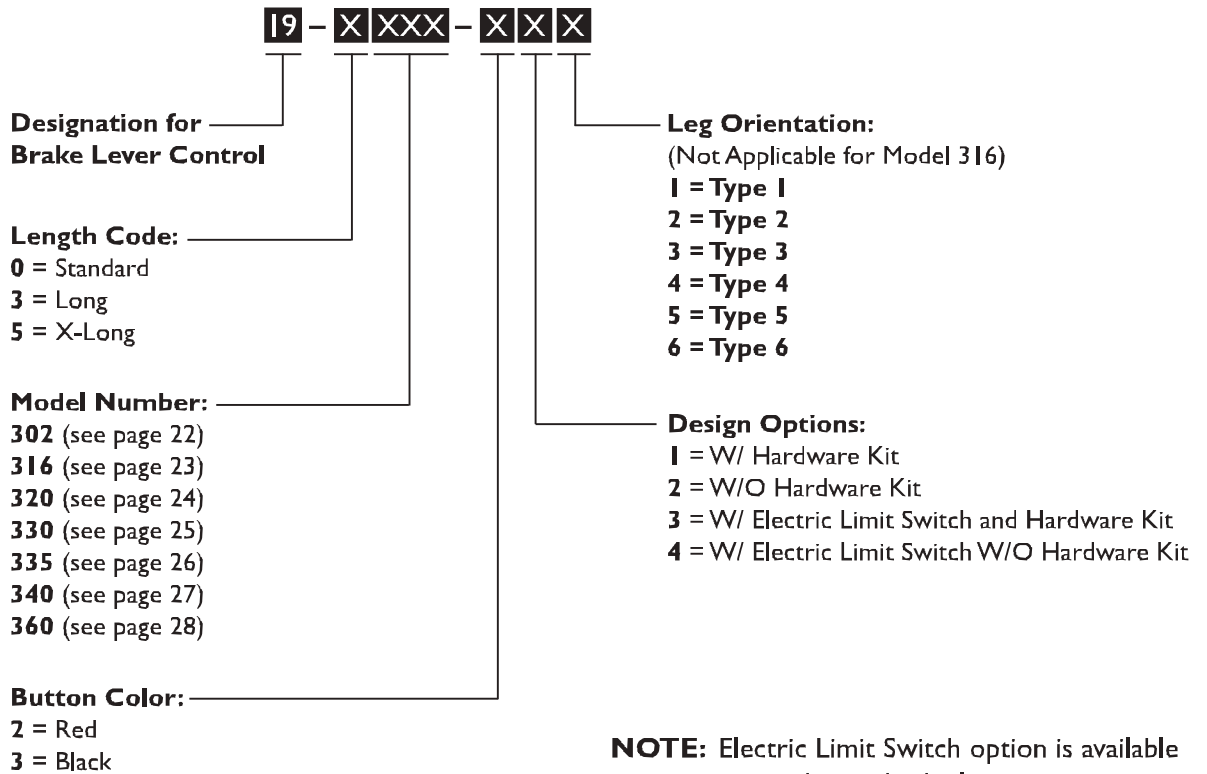

## Ratcheting Brake Le I 302

### Typical Applications and Features

All dimensions are inches (mm)

- Cable Travel = (A) 2.47  
(B) 3.37
- Lever Rotation = 63° max.
- Le (A) 4.5 to 1  
(B) 3.3 to 1
- Hardware Kit  
01-1902-03

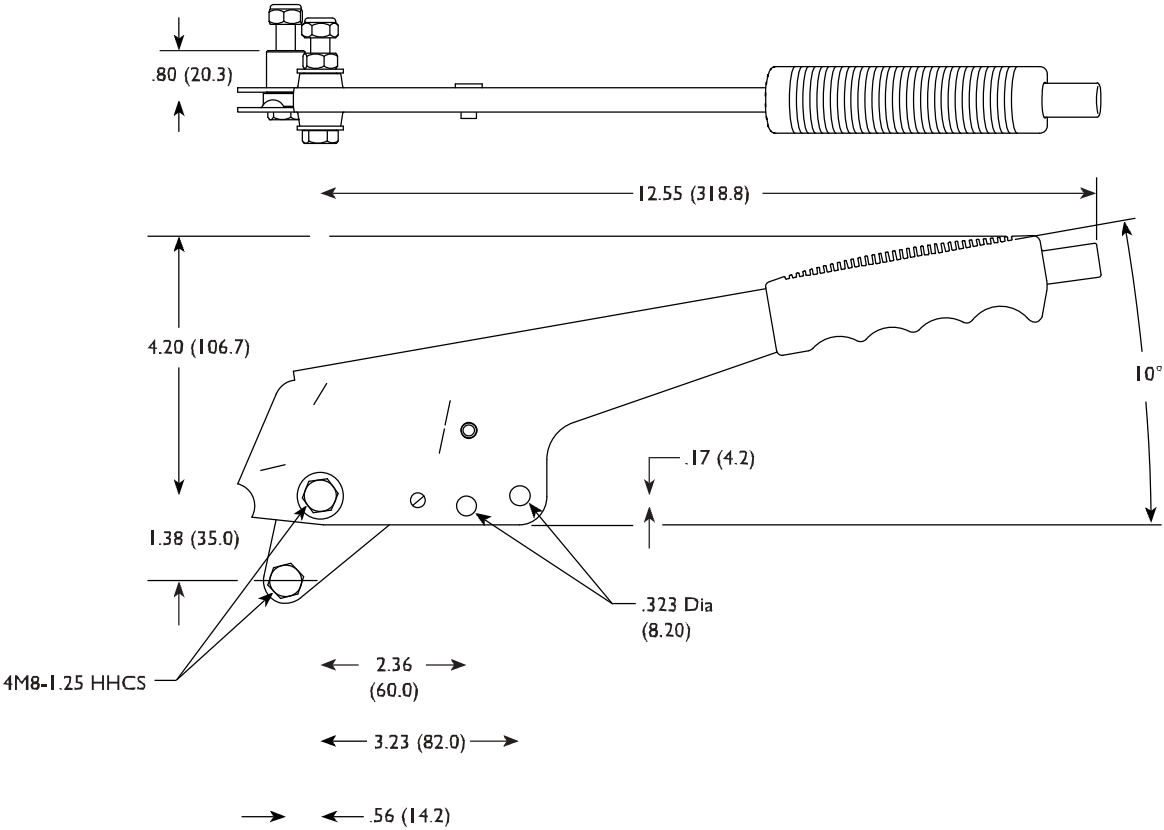

## Ratcheting Brake Le 1316

### Typical Applications and Features

All dimensions are inches (mm)

- Flange mount for lift trucks, golf carts, utility vehicles, lawn and garden tractors, stand alone trailer park brakes.

- Cable Travel = 1.57 inches. (39.9mm)

- Le

Le I

- Hardware Kit  
01-1902-03

- Electric Limit Switch  
80-4004-07  
(See page 30)

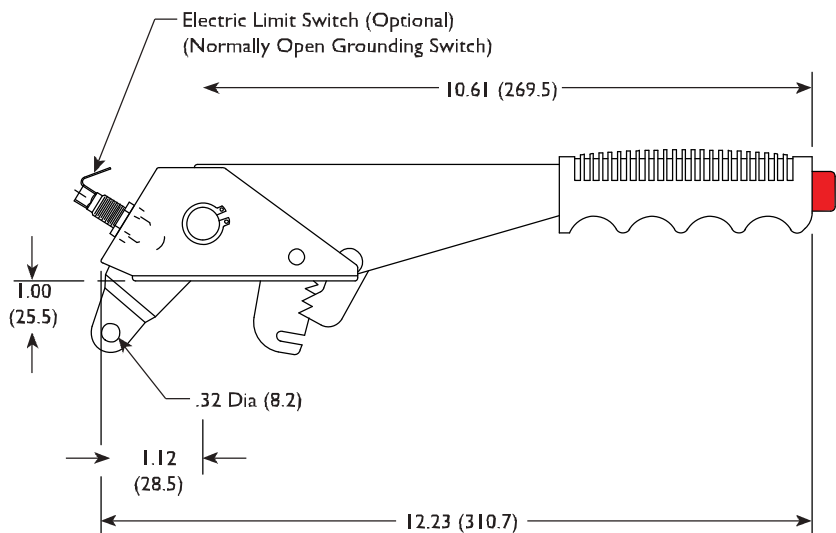
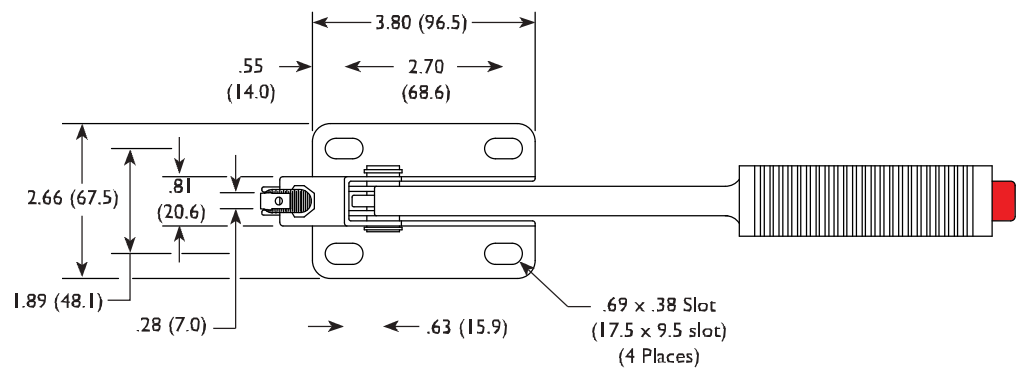



## Ratcheting Brake Lever 1320

### Typical Applications and Features

All dimensions are inches (mm)

- Cable Travel = 1.57 Inches (39.9 mm)

- Le

Le  
X-Long 5.1 to 1

- Hardware Kit  
01-1902-03

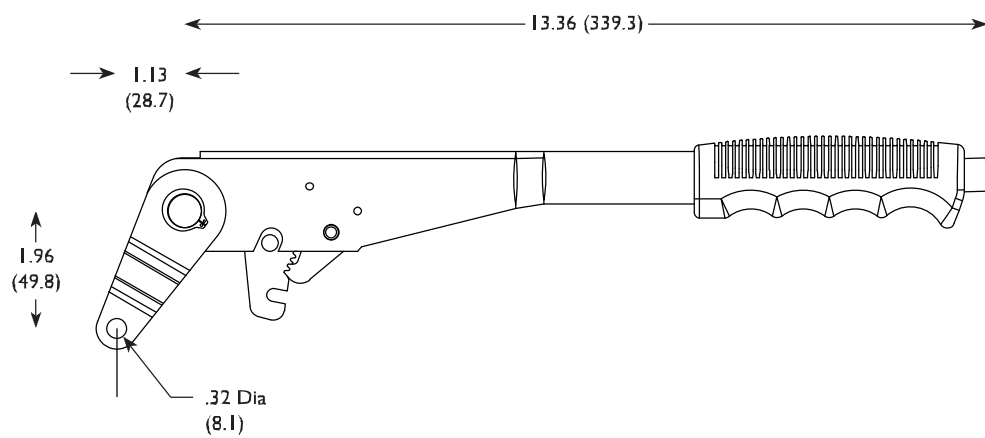
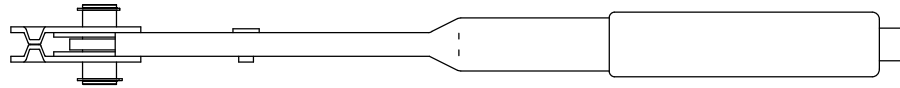

## Ratcheting Brake Le I 330 (L.H.)

### Typical Applications and Features

All dimensions are inches (mm)

- Cable Travel = 1.11 Inches. (28.2mm)
- Le  $7^{\circ}$  Max.
- Lev
 

	I
Long	7.2 to I
X-Long	8.3 to I
- Electric Limit Switch Kit Option  
01-1902-05  
(See page 29)
- Cable Connection Kit  
01-1902-04  
(See page 29)

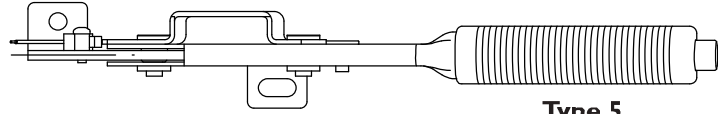

**Type 5**

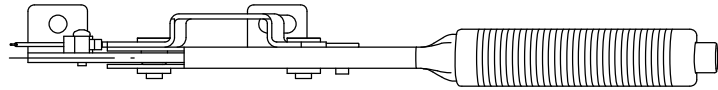

**Type 4**

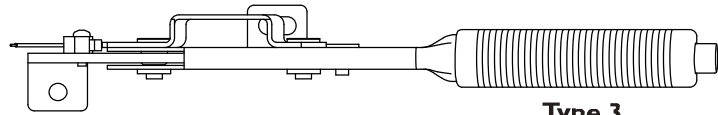

**Type 3**

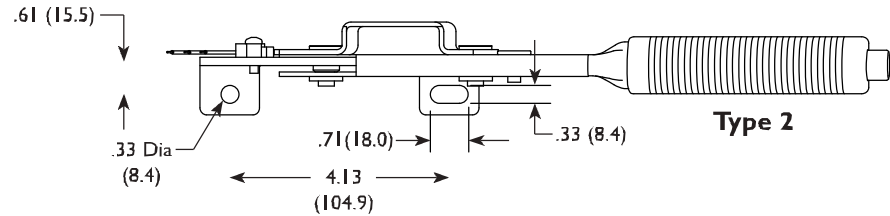

**Type 2**

12.38 (314.5) I9-0330-XXX Standard  
14.00 (355.6) I9-3330-XXX Long  
15.50 (393.7) I9-5330-XXX X-Long

3.89 (98.8) I9-0330-XXX Standard  
4.04 (102.6) I9-3330-XXX Long  
4.17 (105.9) I9-5330-XXX X-Long

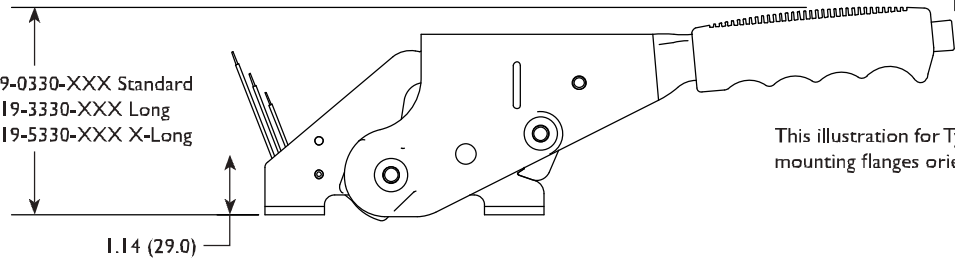

This illustration for Type 2-5 with mounting flanges oriented as shown

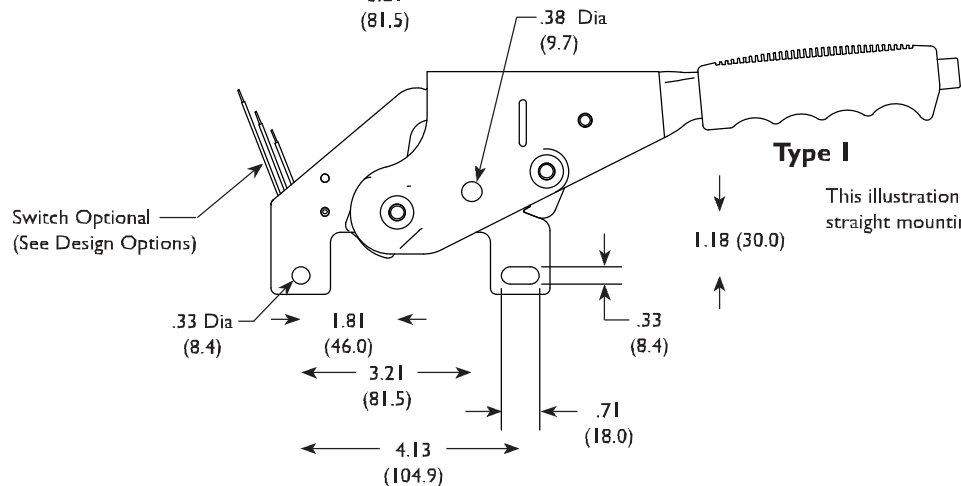

**Type 1**

This illustration for Type 1 for straight mounting flanges only

## Ratcheting Brake Lever I 335 (R.H.)

### Typical Applications and Features

All dimensions are inches (mm)

- Cable Travel = 1.11 Inches (28.2mm)
- Le  $7^{\circ}$  Max.
- Le
 

	I
Long	7.2 to I
X-Long	8.3 to I
- Electric Limit Switch Kit Option  
01-1902-05  
(See page 29)
- Cable Connection Kit  
01-1902-04  
(See page 29)

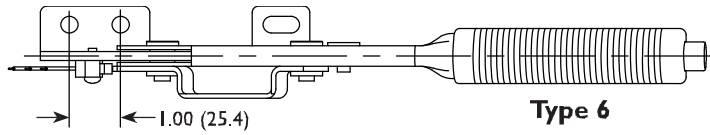

**Type 6**

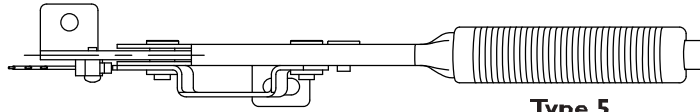

**Type 5**

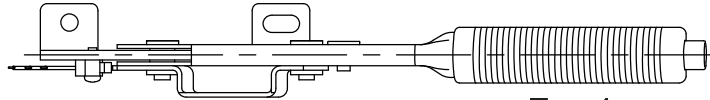

**Type 4**

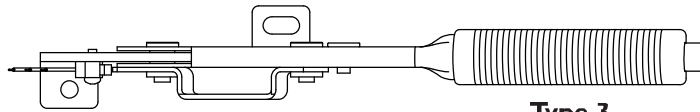

**Type 3**

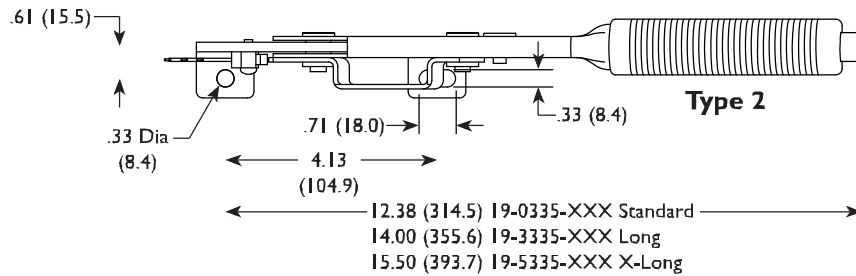

**Type 2**

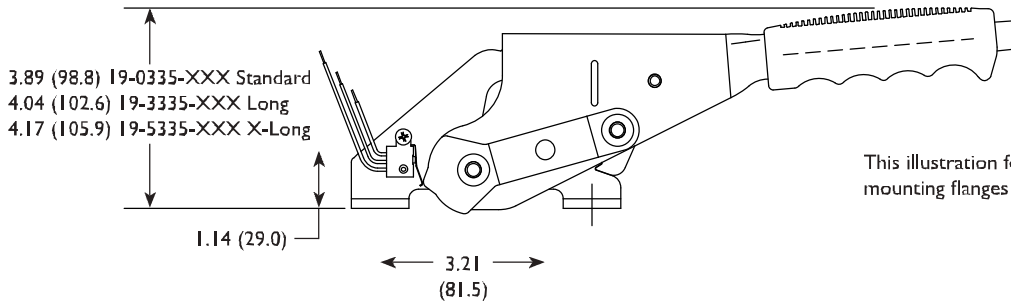

This illustration for Type 2-6 with mounting flanges oriented as shown

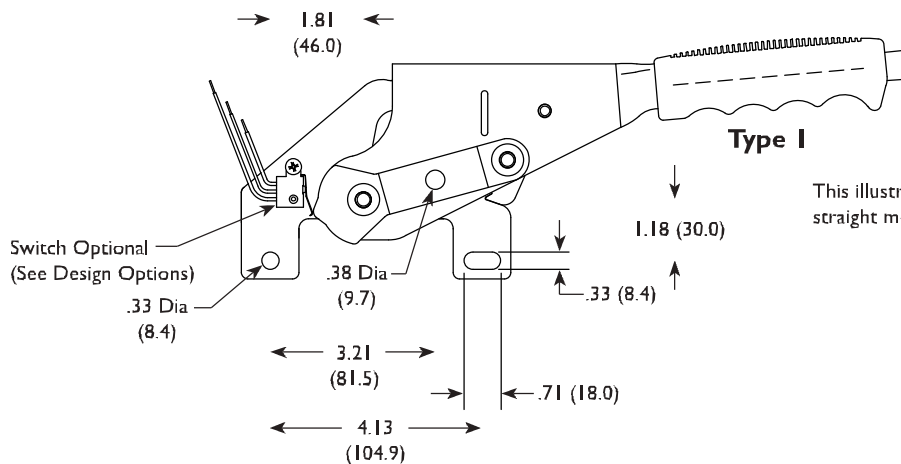

**Type I**

This illustration for Type I for straight mounting flanges only

## Ratcheting Brake Le I 340

### Typical Applications and Features

All dimensions are inches (mm)

- Cable Travel = (A) 1.67 Inches. (42.4mm)  
(B) 2.29 Inches. (58.2mm)
- Lever Rotation = 69° Max.
- Le (A) Standard 6.0 to 1  
(B) Standard 4.4 to 1  
(A) Long 7.0 to 1  
(B) Long 5.1 to 1  
(A) X-Long 8.1 to 1  
(B) X-Long 5.8 to 1
- Electric Limit Switch Kit Option  
01-1902-05  
(See page 29)
- Cable Connection Kit  
01-1902-03  
(See page 29)

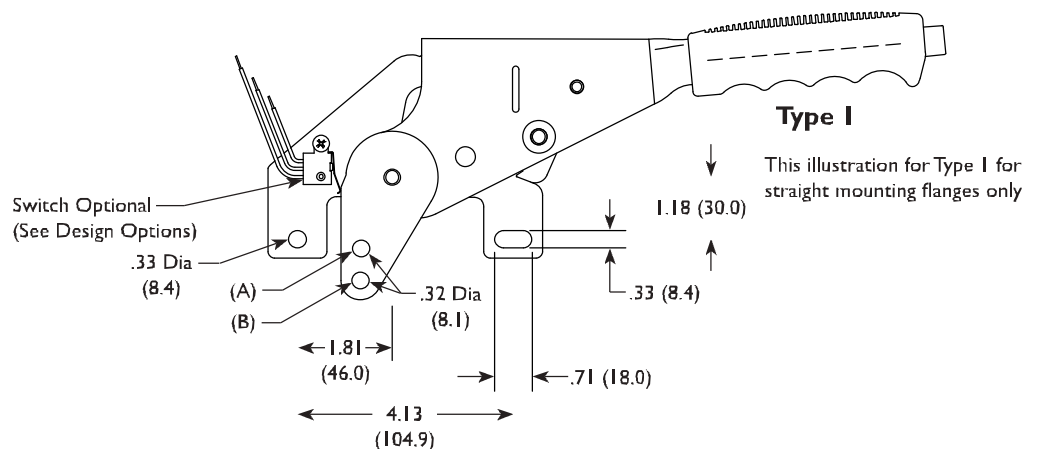
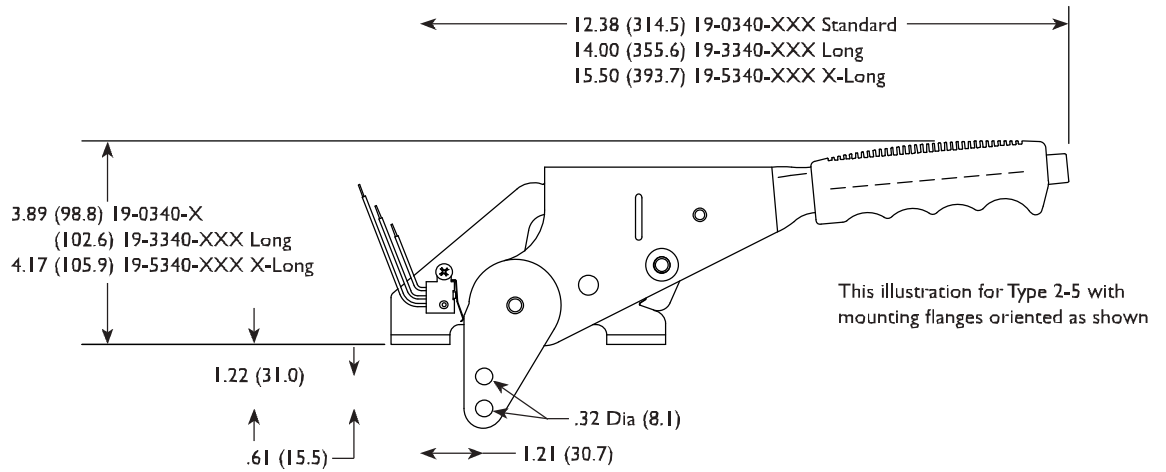
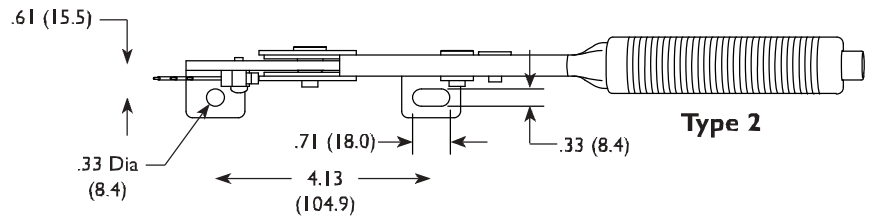
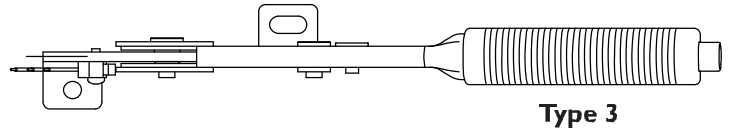
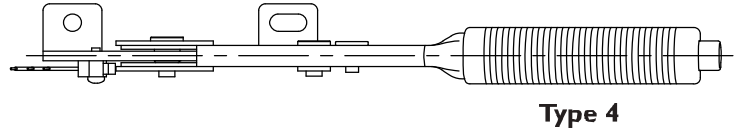
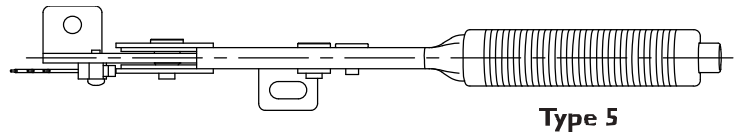

## Ratcheting Brake Le I 360

### Typical Applications and Features

All dimensions are inches (mm)

- Cable Travel = (A) 1.38 Inches. (35.1mm)  
(B) 2.00 Inches. (50.8mm)
- Le
  - (A) Standard 7.1 to 1
  - (B) Standard 4.9 to 1
  - (A) Long 8.3 to 1
  - (B) Long 5.8 to 1
- Electric Limit Switch Kit Option  
(See page 29)

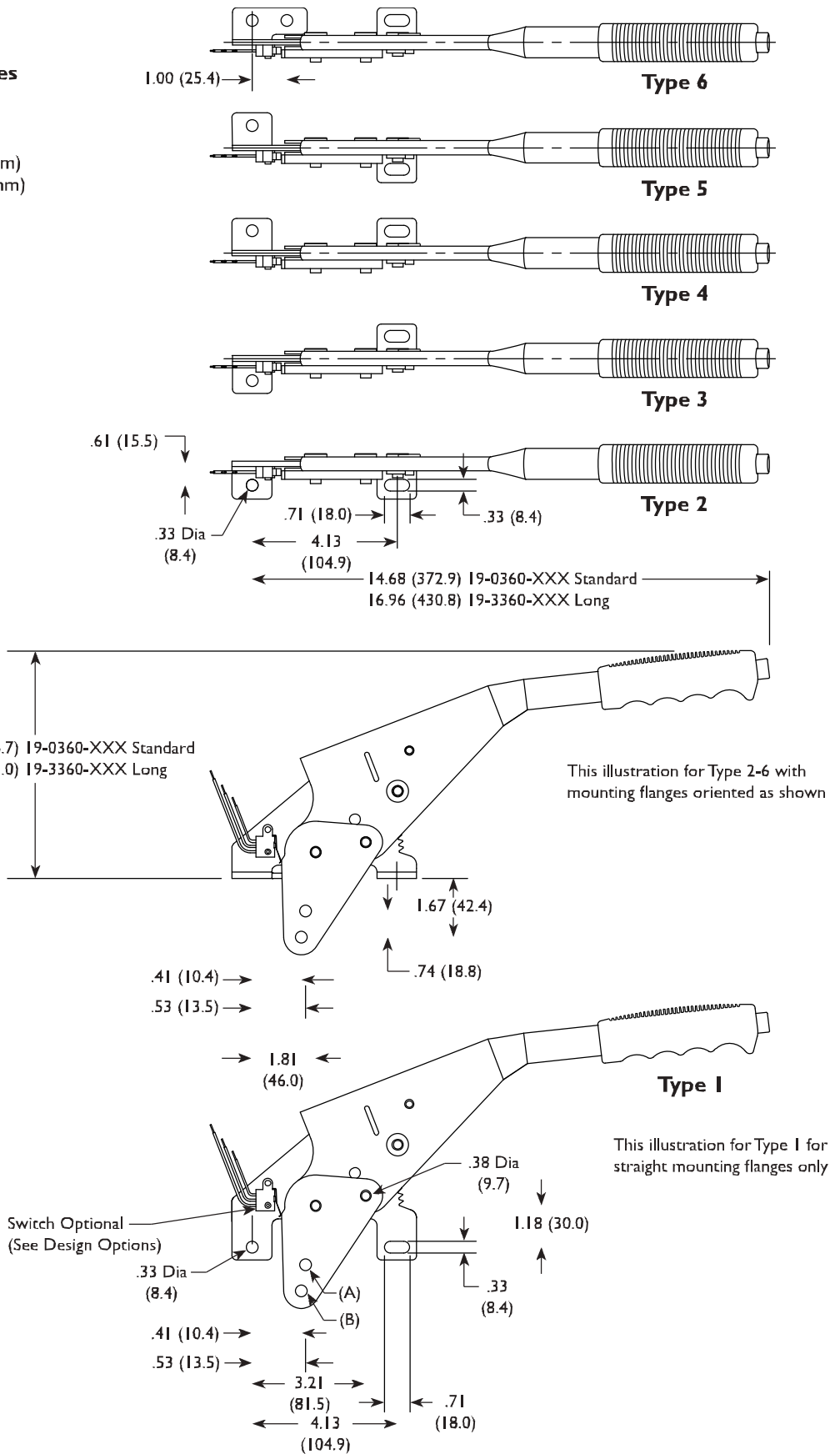



## Electric Limit Switch Kit

Part Number 01-1902-05

### Typical Applications and Features

- Designed to fit any ratcheting brake lever manufactured after January 1, 2006. (Except Model 316 see page 27)
- Kit includes (2) mounting screw (80-0021-06)

Rated 1A@30VDC (Resistive Load)

Red = Normally Closed

Blue = Normally Open

Black = Common

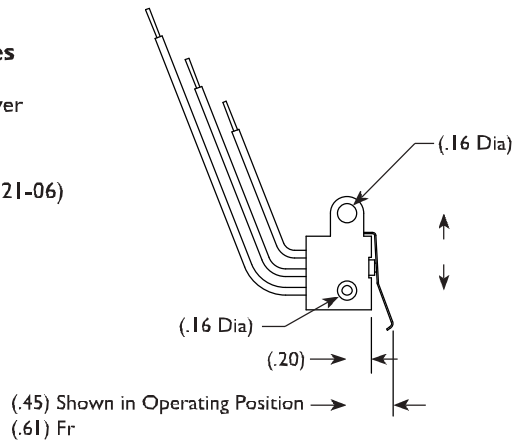

## Schematic

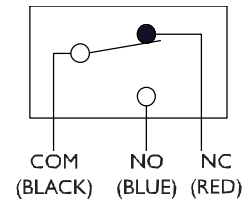

## Brake Cable Clip

- Part Number 80-4027-01
- For use with .125 Dia Core and Cable Slug Fitting 21-1086-28

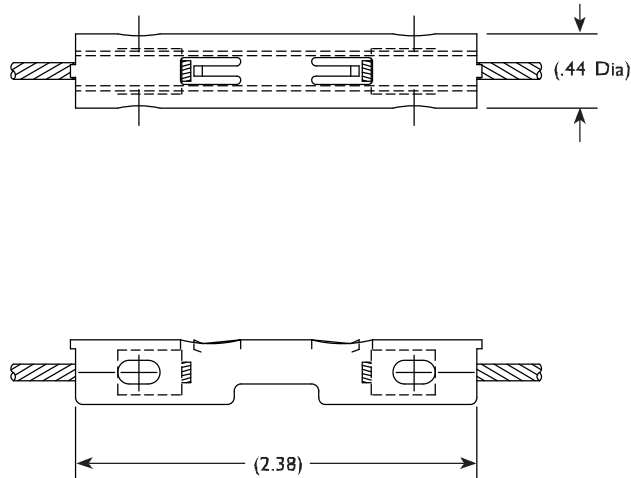

## Cable Connection Kits

- Part Number 01-1902-03
- For models 19-0316, 19-0340 & 19-0360

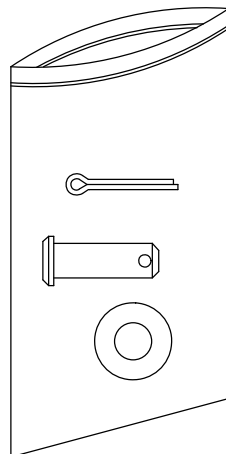

- Part Number 01-1902-04
- For models 19-0330 & 19-0335

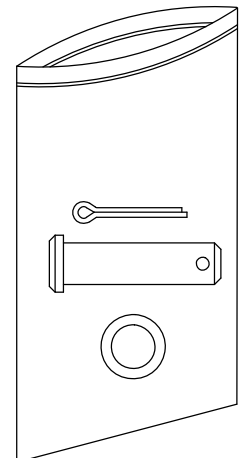

**Electric Magnetic Switch Kit**

**Part Number - 01-5001-13**

**Typical Applications and Features**

(Items listed in parentheses not included in kit)

- Designed to fit in any over-center brake lever manufactured after January 1, 2000.
- Switch Specifications: S.P.D.T.

Temperature Range: -40° to 105° C

Designed to operate in hostile environments and is weather resistant.

**Switch Ratings:**

Voltage: 175 VDC (Max. Switching)  
 200 VDC (Min. Breakdown)  
 Current: .25 Amps (Max. Switching)  
 1.5 Amps (Max. Carrying)  
 Wattage: 5 Watts Max.

Blue = Normally Closed  
 Black = Normally Open  
 White = Common

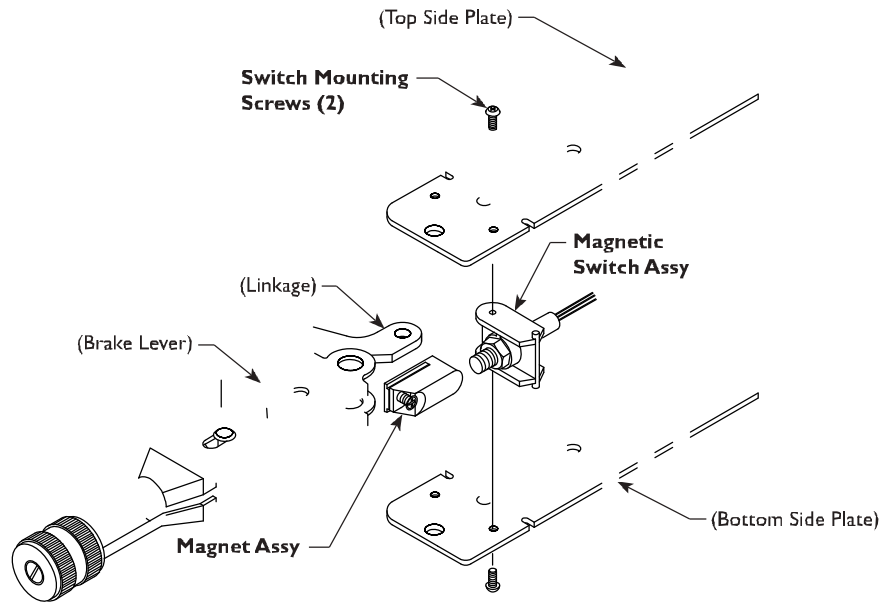

**Model 316 Electric Limit Switch**

**Part Number - 80-4004-07**

**Typical Applications and Features**

- Designed to fit in any Model 316 brake lever manufactured after January 1, 2000
- Switch Ratings:  
 Voltage: 24 VDC  
 Current: .3 Amps

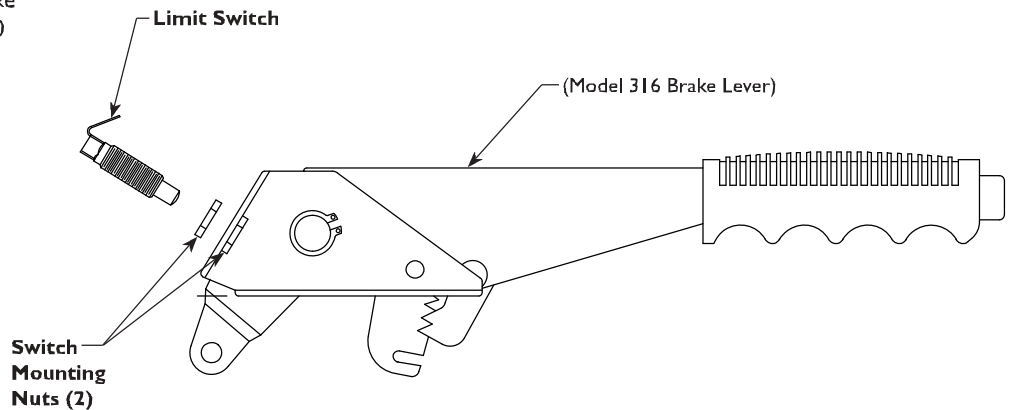

## Features and Specifications

All inline switches utilized internal cable seals to retain lubrication and exclude contaminants.  
 All inline switches are externally sealed to exclude contaminants away from contacts and cable.  
 Switches are internally spring loaded to break contact when the load is released.  
 Switches are overload protected and capable of repeatedly enduring 1200 lb. cable loads.

### 18-0101-01 Snap-In Fitting Switch

Capacity: 1.0 AMP @ 12VDC  
 Mounting: .12/.18 grip, Ø.57/.58 mounting hole  
 For use in applications formerly reserved for 18-0014-04 snap-in fittings.

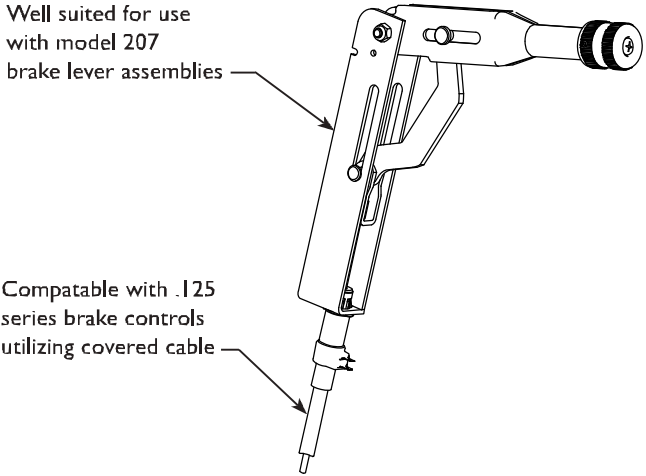
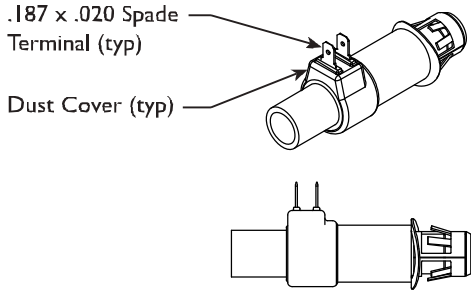

### 18-0102-01 Clamp Type Fitting Switch

Capacity: 1.0 AMP @ 12VDC  
 Mounting: Ø.50 x .75 long body for clamping  
 For use in applications formerly reserved for 24-2406-01 clamp type conduit fittings.

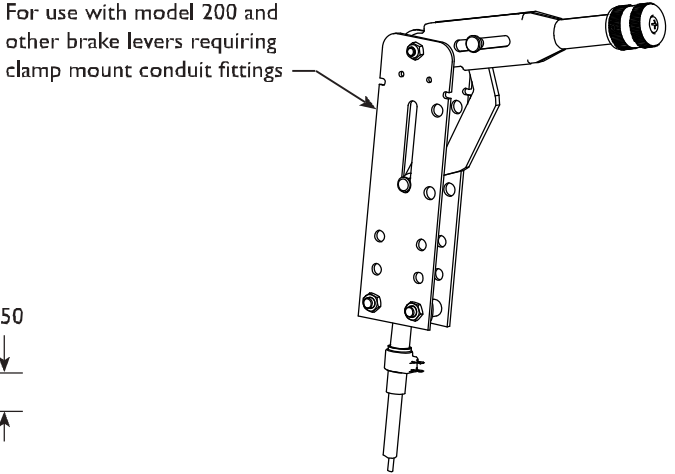
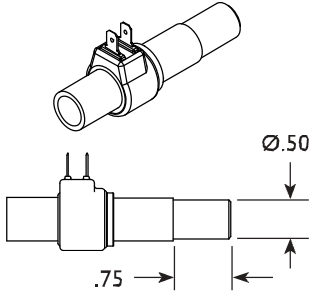

### 18-0103-01 Bulkhead Fitting Switch

Capacity: 1.0 AMP @ 12VDC  
 Mounting: 9/16-12 UNC x 1.25 long (Requires 2 ea. 80-0006-72 hex nuts)  
 For use in applications formerly reserved for 21-2405-01 bulkhead conduit fittings.

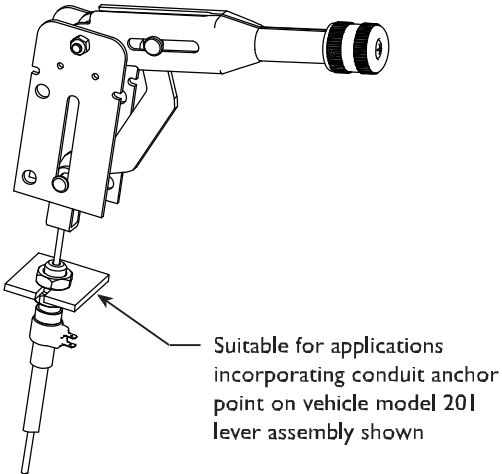
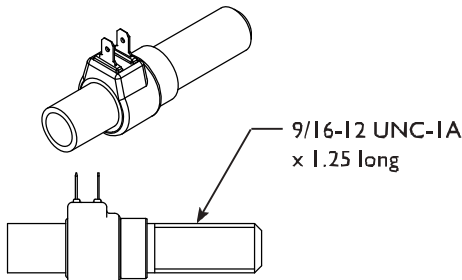

# TAKE A LOOK AT OUR WESCON PRODUCTS



## Push-Pull Cables Control Systems

Proven technology and years of experience have gone into making the Wescon push-pull cables top of the line in durability and dependability. Polyethylene covers and a variety of conduit constructions can be customized to fit your specific cable usage. Other optional plastics or nylon can be added to suit your environmental, corrosion resistant or extreme temperature applications.



## Panel Control Systems

Our Power Take-off (PTO), Turn-to Lock and Vernier control systems are all backed by a one-year replacement warranty and a wide range of options to meet your specific needs. The PTO is designed for your remote PTO shifting operations and its rugged polymer conduit cover is built to withstand harsh environments. In severe vibration applications where a reliable lock is needed, the Turn-to-Lock can be used for chokes, throttles, engine shut-offs and valves. And the latest model of our Vernier control system gives you the capability of precise RPM settings with a secure construction that reduces corrosion and temperature hazards. Contact your Wescon representative for specifications, prices and delivery dates.



## Remote Valve Control Systems

Look to Wescon for your remote valve applications. Wescon's Remote Valve Control (RVC) has been engineered to place versatility in the hands of the installer. Our center or end-locking feature, thumb activated by the "Big Red Button", can help your system meet OSHA Standards. We also offer options such as bent levers to fit your mounting requirements, electric switches installed in the lever, or an adjustable friction device to "customize" your lever resistance. A wide selection of control heads, conduit, connection hardware kits, and mounting systems makes it easy to choose Wescon for your RVC application.



## Light Duty Cable Control Systems

Our light duty cable control systems are engineered to help your equipment run smoother while complementing the functionality and the aesthetics of your product. Call the Wescon team to help you design controls that add to the marketability of your products.



ISO 9001 CERTIFIED

## WESCON CONTROLS

P.O. Box 7710 Wichita, Kansas 67277  
316-942-7266 or call toll free 1-800-835-0160  
Fax 316-942-5114  
[www.wesconproducts.com](http://www.wesconproducts.com)